

# AMPEX

MODEL 350

## **OPERATION AND MAINTENANCE MANUAL**

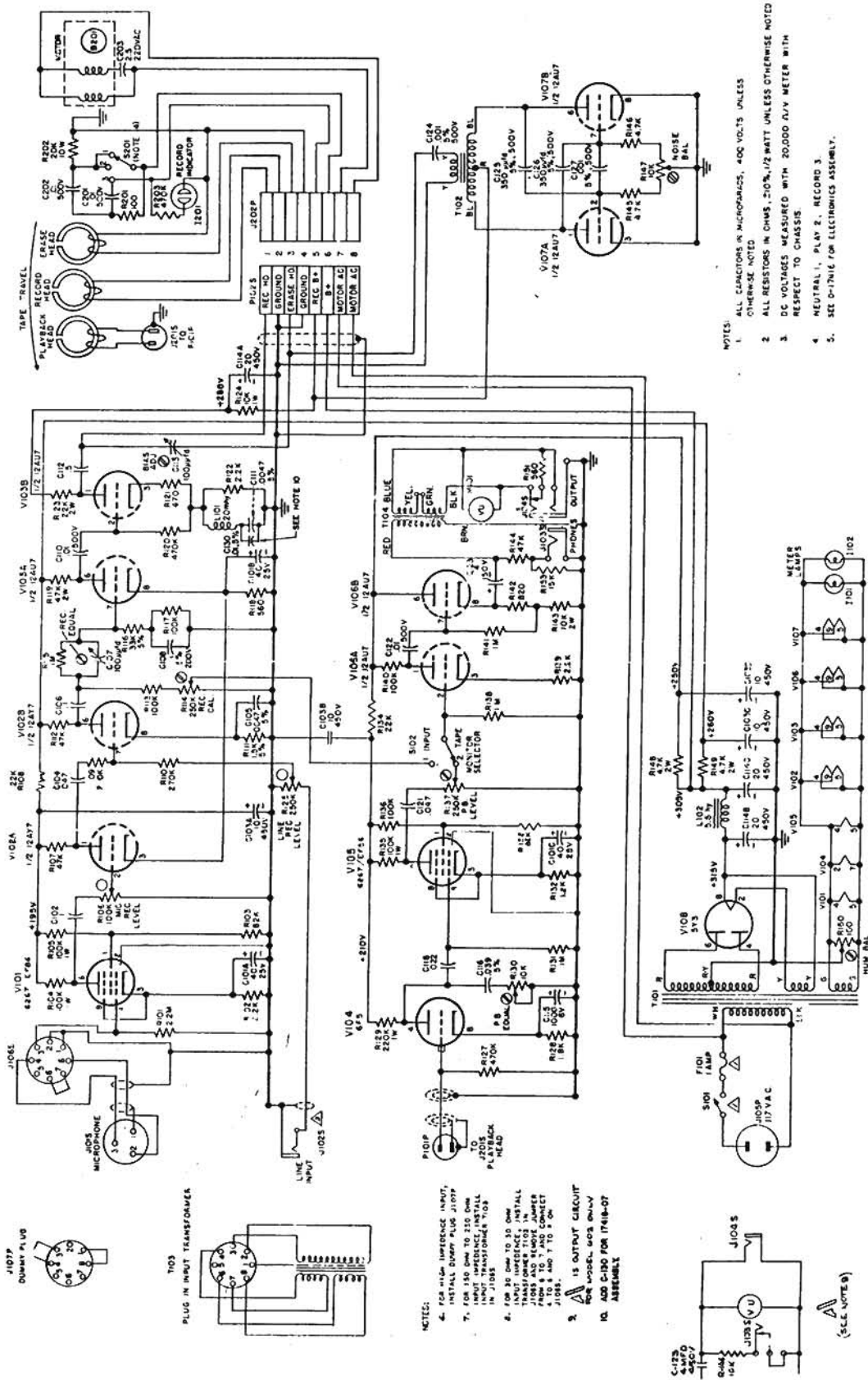

- NOTES:
1. ALL CAPACITORS IN MICROPHONES, 400 VOLTS UNLESS OTHERWISE NOTED
  2. ALL RESISTORS IN CHAS. 20% 1/2 WATT UNLESS OTHERWISE NOTED
  3. DC VOLTAGES MEASURED WITH 20,000 Ω/V METER WITH RESPECT TO CHASSIS
  4. NEUTRAL 1, PLAY 2, RECORD 3
  5. SEE 0-17116 FOR ELECTRONICS ASSEMBLY.

- NOTES:
4. FOR HIGH IMPEDANCE INPUT, INSTALL DUMMY PLUG J107P
  7. FOR 150 OHM TO 210 OHM INPUT IMPEDANCE, INSTALL INPUT TRANSFORMER T101 IN J105
  8. FOR 30 OHM TO 10 OHM INPUT IMPEDANCE, INSTALL INPUT TRANSFORMER T101 IN J105 AND REMOVE JUMPER FROM 8 TO 7 AND CONNECT J105A AND 7 TO 8 ON J105A
  9. IS OUTPUT CIRCUIT FOR MODEL 605 ONLY
  10. USE C-129 FOR IT-18-07 ASSEMBLY

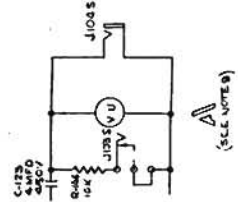
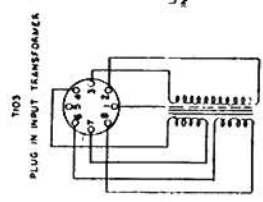
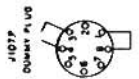

## SECTION 1

### SPECIFICATIONS

The Ampex Model 350 magnetic tape recorder is a two-speed audio recorder designed for use with standard 1/4 inch tape. Model 350 is available in console, two-case portable, and rack-mount styles, all with either full or half track heads. The performance specifications and characteristics of the machine are as follows:

#### TAPE SPEED

7-1/2 inches per second and 15 inches per second or

3-3/4 inches per second and 7-1/2 inches per second.

#### FREQUENCY RESPONSE

<u>Speed</u>	<u>Response</u>
3-3/4"	+ 2 db 50 to 7,500 cycles - 4 db 30 to 15,000 cycles
7-1/2"	+ 2 db 40 to 10,000 cycles - 4 db 30 to 15,000 cycles
15"	+ 2 db 30 to 15,000 cycles

#### SIGNAL-TO-NOISE RATIO

<u>Speed</u>	<u>Max. Record Level to Unweighted Noise</u>	<u>Peak Record Level to Unweighted Noise</u>
3-3/4"	60 db	50 db
7-1/2"	Full Track 70 db Half Track 65 db	Full Track 60 db Half Track 55 db
15"	Full Track 70 db Half Track 65 db	Full Track 60 db Half Track 55 db

The peak record level is defined as that level at which the overall (input to output) total RMS harmonic distortion does not exceed 3% when measured on a 400 cycle tone. Noise is measured when erasing a signal of peak recording

level in the absence of new signal. Thus, bias and erase noise are included as well as playback amplifier noise. All frequencies between 50 and 15,000 cycles are measured.

#### FLUTTER AND WOW

<u>Speed</u>	<u>Flutter and wow</u>
3-3/4"	.3 %
7-1/2"	.25 %
15"	.2 %

The flutter and wow measurements include all components between 0 and 300 cycles using an RMS meter calibrated to read the peak value of constant amplitude sine wave flutter.

#### PLAYING TIME WITH NARTB 10-1/2 INCH REELS (2,400 feet of tape)

<u>Speed</u>	<u>Half Track</u>	<u>Full Track</u>
3-3/4"	4 hrs. 16 min.	2 hrs. 0 min.
7-1/2"	2 hrs. 8 min.	64 min.
15"	64 min.	32 min.

STARTING TIME: Instantaneous (tape accelerates to full speed in less than 1/10 second.)

STOPPING TIME: When playing at the 15 inches per second speed, the tape moves less than two inches after pressing the "Stop" button.

PLAYBACK TIMING ACCURACY: + .2% or + 3.6 seconds in a thirty minute recording.

REWIND TIME: Approximately one minute for the full 2,400 foot NARTB reel.

CONTROLS: The tape motion is controlled by four pushbuttons: Start, Stop, Fast Forward, and Rewind. A separate Record button energizes the record circuits, which will drop out when the machine is stopped. The tape speed is changed by a Motor Speed Switch. An Equalization Switch changes the amplifier equalization appropriately for the various tape speeds. A Reel Size switch provides proper tape tension for either the NARTB 10-1/2 inch reel or the RMA 5 inch and 7 inch reels.



RECORD INPUT: A switch allows the recorder to accommodate either microphone level low impedance input or to bridge a 600 ohm + 4 VU line, balanced or unbalanced. Minus 80 dbm at the microphone input will produce the recommended record level.

PLAYBACK OUTPUT: Plus 4 VU output into 600 ohms balanced or unbalanced. Will feed a high impedance amplifier directly with approximately one volt.

PLUG-IN HEAD HOUSING: The erase, record, and playback heads are contained in a single plug-in head housing.

MONITORING: Independent record and playback systems allow the tape to be monitored while recording. A phone jack is provided to monitor either the record input signal before or during recording, or the output signal from the playback head while recording or during playback. An A-B switch is incorporated in order that direct comparison can be made between the original program and the recorded program. The same switch transfers a 4 inch VU meter for level comparison and monitoring. The VU meter is also used to read bias and erase current.

POWER REQUIREMENTS: The half and full track machines require 2.7 amperes at 115 volts AC. Machines are available for either 50 or 60 cycle operation.

DIMENSIONS AND WEIGHT:

Rack Mounted:

(Standard 19 inch wide panel with commercial notching.)

Tape Transport: 15-3/4 inches of rack space, weight 50 lbs.

Electronic Assembly: 7 inches of rack space, weight 18 lbs.

Power Supply: 3-1/2 inches of rack space, weight 8 lbs.

Console:

Height - 48" (maximum)

Depth - 28-1/2" (maximum)

Width - 24-1/2"

Weight - 168 pounds

Two Case Portable

Tape Transport Case

Height - 15-1/2"  
Depth - 17"  
Width - 20-1/4"  
Weight - 69 pounds

Electronic Assembly & Power Supply Case  
(with extra space for mixer or cable storage)

Height - 19"  
Depth - 13"  
Width - 21"  
Weight - (less mixer) 42 pounds

## SECTION 2

### INSTALLATION

#### 2.1 MOUNTING AND INTERCONNECTING

##### IMPORTANT:

Before operating the recorder, read the following sections on INSTALLATION and OPERATION.

##### CAUTION:

Do not attempt to lengthen the head cables. Additional cable capacity will affect the frequency characteristics.

- A. Console Models: Cabinet and components are packaged separately. Assembly hardware is provided. Assemble as follows: (1) Install Tape Transport in cabinet frame and secure with 8 oval-head screws and finishing washers. (2) Insert 2 springs in holes in electronics frame of cabinet (3) Install Electronic Assembly, completing required plug-in connections between it and the tape transport. Use four knurled nuts to secure assembly to cabinet. (4) Remove back panel of cabinet and install Power Supply on small shelf at rear. Secure with two round-head screws. Plug Power Supply Cable into Electronic Assembly. (5) Plug input, output, and AC power cables into rear of Electronic Assembly and replace back panel of cabinet so that all cables run freely through the semi-circular cuts in its lower edge. **IMPORTANT:** The back of the console cabinet must be spaced at least 4" from the wall to permit proper ventilation.
- B. Two Case Portable Models: The portable machine is shipped in a ready to operate condition, except for the connections of interconnecting cables.

To operate the recorder place the Mechanical Assembly Case to the right of the Electronic Assembly Case. Unlatch and remove the top cover and open the cable access door on the left side of the Mechanical Assembly Case. Unlatch and remove the front and rear covers on the Electronic Assembly Case.

Uncoil the interconnecting cables from behind the cable access door and plug them into mating receptacles at the rear of the Electronic Assembly.

Connect the input, output, and AC power to the rear of the Electronic Assembly.

**C. Rack Mount Models:** The rack mount machine should be mounted on a standard 19 inch relay rack with the Mechanical Assembly above the main Electronic Panel. The Electronic Power Supply Panel should be mounted directly above the Mechanical Assembly to eliminate the possibility of 60 cycle field from entering the Electronic Assembly.

If two Model 350 Recorders are to be mounted on a Standard rack, the following placement is recommended (starting at the top of the rack):

1. Install a spacer panel at the top of the rack if desired.
2. Install below this panel the Mechanical Assembly for machine #1.
3. Install the Electronic Assembly for machine #1.
4. Install a spacer panel.
5. Install the Mechanical Assembly for machine #2.
6. Install the Electronic Assembly for machine #2.
7. Install a spacer panel.
8. Install both Power Supply Panels at the bottom.  
(the cable on the power supply for the upper recorder will have to be extended in length. Extension cable #3814 is available for this purpose.)

The numbers set off in parentheses in the following text are reference numbers that refer to the Parts List (Section 6) and the figures in the rear of this book.

## 2.2 AC POWER:

Connect the Power Cable, Catalog #2413, from the AC Power Input Connector (J409P) on the Electronics Assembly to a source of 115 Volt AC power.

**IMPORTANT:** This machine is available for either 50 or 60 cycle operation. The power line frequency is indicated on the serial number plate which is located on the Power Supply Panel for rack mount machines, on the exterior of each case in the portable machines, and on the back of the console cabinet.

## 2.3 OUTPUT: Refer to Figure 1 or 2.

### A. For Studio Line:

Plus 4 VC, 600 ohm line output, balanced or unbalanced, is available across Terminals 2 and 3 of the Line Out Connector, (J404P). Pin 1 is the chassis ground. If unbalanced output is desired, tie either side of the

line to ground. It is necessary to supply 600 ohm termination to this output at all times in order to maintain correct meter calibration while recording or playing back. Therefore, if the output is not feeding a terminated line, or if the output is not connected, such as on remote pickups, the Line Out Termination Switch, (S404), must be switched to ON.

B. For Connection to High Impedance Amplifier Input:

Connect pin 3 of the Line Out Connector, (J404P), to the high side of the amplifier input. Strap pins 1 and 2 of the connector and connect to the ground side of the amplifier input. The Line Out Termination Switch (S404), must be left in the position designated ON at all times, as explained in A above.

2.4 INPUT: Refer to Figures 1 or 2 and 5.

The following inputs are provided.

A. Microphones:

Any low impedance microphone, the nominal impedance of which is in the range of 30 to 250 ohms can be plugged in directly. Connect the microphone to pins 2 and 3 of the Input Connector, J401S). Connect cable shield to pin 1. Place the Input Transfer Switch, (S401), to the MIC position.

The microphone input transformer is strapped for the optimum step up for a 150 to 250 ohm source. In the case of microphones having 50 ohms or less impedance, 6 db additional gain can be obtained by strapping the input as shown in Figure 5B. This is not usually necessary, however, and should not be done unless insufficient gain is found to exist should the input be fed from a source impedance greater than 50 ohms. **IMPORTANT.** R402 and R403 will have to be changed to 24 ohms and R401 and R404 to 68,000 ohms to maintain a flat response on Balanced Bridging when the transformer is strapped for 50 ohm source impedance.

High impedance microphones are not recommended for use in this equipment. In general, the quality obtainable from high impedance microphones is not satisfactory for professional work. In the event that it becomes necessary to connect a high impedance microphone, the input circuit will have to be re-wired as shown in Figure 5A.

B. Bridging a Balanced Studio Line:

Connect a balanced line to pins 2 and 3 of the Input Connector, (J401S). Pin 1 is ground. Place the Input Transfer Switch, (S401), in the BALANCED

BRIDGE position. Input levels of minus 10 to plus 10 VU can be accommodated. The load placed on the line is approximately 300,000 ohms.

For bridging higher or lower level lines, an external bridge can be wired in the line to the machine. This would consist of two resistors, the value of which should be from 15,000 to 30,000 times the RMS program voltage, in series with each side of the line. A 24 ohm  $\pm 5\%$  resistor should terminate each leg of the output side of the two bridging resistors. The junction of the two 24 ohm resistors should go to chassis ground. The output of the bridge must be fed to the microphone input of the recorder. The input of the recorder may be connected for any impedance from 50 to 250 ohms.

### C. Bridging an Unbalanced Source:

Connect an unbalanced line, radio tuner, etc., to pins 1 and 3 of the Input Connector (J401S). Pin 1 is the ground side. Place the Input Transfer Switch, (S401), in the UNBALANCED BRIDGE position. This connection provides a 60,000 ohm bridging input for any RMS program voltage greater than 1/2 volt. To increase the input impedance above 60,000 ohm, a series resistance of 330,000 ohms can be wired into the input plug in series with pin 3 and the input cable. This will necessitate an input voltage of at least 2-1/2 volts RMS. It is important that this resistor be physically placed in the cable connector that plugs into the Recorder Input (J401S) in order that the cable capacity be on the input side of the resistor.

### 2.5 PHONES:

Any sensitive head phones can be plugged in the Phone Jack (J403S), provided for monitoring the incoming line or playback output.

### 2.6 REMOTE CONTROL: Refer to Figure 15.

The operation of the Tape Transport mechanism can be remote-controlled through the use of an Ampex Catalog #5763 or 5763-1 Remote Control Unit. The catalog #5763 unit is supplied in a wooden case and is completely wired, ready to plug into the Remote Control Connector, (J502S), on the front of the Tape Transport Circuits Assembly. The catalog #5763-1 unit is mounted on a flat plate for installation in studio consoles, and is not wired. To install, wire as shown in Figure 15, and plug into J502S.

NOTE: Whenever the Remote Control unit is not connected, the Dummy Plug (P502P), supplied with the machine, must be plugged into J502S.

## 2.7 60 CYCLE AMPLIFIER: (For Drive Motor Power)

The Ampex Model 375 Precision 60 cycle amplifier or Model 331A Speed Lock Equipment can be plugged in directly at J5033. No other connections are necessary. If either of these units is used with the recorder, the Control Circuits Fuse (F402) must be increased to 5 Amperes. Do not remove the Dummy Plug (P503 P) unless one of these units is to be connected.

## 2.8 ACCESS TO CONSOLE CABINET:

WARNING: Before opening the console or portable cases, disconnect AC power.

Complete accessibility for inspection or service is provided to the top and bottom of the Electronic Assembly and bottom of the Mechanical Assembly. See Figure 16 for an illustration of the Console Cabinet opened for full accessibility.

### Opening Procedure:

1. Remove the four cap nuts securing the Electronic Assembly to the Cabinet.
2. Pull the Electronic Assembly up until the runners are free of the slots. Re-insert the runners in the short slots immediately in front of the two lower studs.
3. Remove the two set screws holding the chassis bottom plate. The bottom plate hinges separate at the rear if it is desired to remove the plate completely.
4. The frame on which the Mechanical Assembly is mounted can be raised 90 degrees or more, and held in place by a slide bolt on the lower left underside of the frame.
5. The Power Supply is accessible through the rear of the console when the sliding panel is removed.

## 2.9 ACCESS TO UNDERSIDE OF MECHANICAL ASSEMBLY IN T/C CASE PORTABLE

Stand Mechanical Assembly Case on end as shown in Figure 17. Release the latches holding the center divisions of case. Open to approximately 90°. Care must be taken to insure that cables can pass through cable compartment into the main cabinet freely.

## 2.10 OVERALL PERFORMANCE CHECK: (Read Section 3 on OPERATION before making these checks.)



The following procedure is recommended for checking the performance of this recorder at the time of installation and as necessary thereafter.

A. Overall Frequency Response:

Thread a new reel of tape on the machine. Equalization curves for the Record and Playback Amplifiers are shown in Figures 6 and 7. Entirely satisfactory results can be obtained from any professional quality tape.

1. 3-3/4 and 7-1/2 Inch Response

DUE TO THE NATURE OF THE PRE-EMPHASIS IN THE RECORD CIRCUIT, TAPE SATURATION WILL OCCUR AT THE HIGH FREQUENCIES UNLESS THE RESPONSE CHECK IS MADE AT LEAST 20 DB BELOW NORMAL OPERATING LEVEL.

Therefore, check the response with a sensitive meter such as a Hewlett-Packard 400C connected to the output. In absence of a sensitive meter, a standard VU Meter preceded by a flat amplifier with at least 20 db gain can be used. Response will be within the limits indicated in the Specifications.

2. 15 Inch Response

Make the response check approximately 10 db below operating level to avoid saturation effects. Response will be within the limits indicated in the Specifications.

B. Overall Noise Measurements:

Overall wide band noise should be measured with a Vacuum Tube Voltmeter such as Hewlett-Packard 400C while playing back a tape that has previously been erased on the machine.

First: Erase the tape with the input to the Record Amplifier shorted. Rewind and play this tape back. Performance should fall within the limits specified under SIGNAL-TO-NOISE RATIO in Section 1. No attempt should be made to measure wide band noise while simultaneously recording and playing back as leakage of the 100 KC bias into the playback head may interfere with the measurement.



C. Distortion:

Overall distortion can be measured by connecting any standard distortion measurement apparatus across the output. The readings from a wave analyzer or selective frequency distortion meter will be more accurate than those from a null type instrument at lower distortion levels. Distortion readings are somewhat dependent on tape. A reading of 1% is normal at operating level while a reading of 3% is normal at 6 db above operating level.

D. Flutter and Wow:

Flutter and Wow are produced by periodic irregularities in tape speed and appear as cyclic frequency deviations in recording or reproduction. They can be measured by means of any standard flutter bridge. Variations in amplitude as indicated on level measurements do not constitute flutter and are entirely due to tape coating variations. Readings will be well under .2% at 15 inch, .25% at 7-1/2 inch, and .3% at 3-3/4 inch speed.

For more information on alignment or performance checking, refer to Section 5.

## SECTION 3

### OPERATING PROCEDURE

#### 3.1 REEL SIZE AND REEL KNOBS:

The Model 350 is equipped to handle either the NARTB 10-1/2" reel of tape or the smaller RMA 5" and 7" sizes. The Reel Size Switch (S504) adjusts tape tension appropriately for the reel size used. On console or portable machines, position the small reels on the turntable engaging the turntable keys. For the large 10-1/2" reels, use the Editing Knobs (catalog #1917) that have been provided. Rack mount machines are supplied with Hold-Down Knobs (catalog #4402) for both small and large reels.

NOTE: Always use reels of the same size on both turntables. Operation with one large and one small reel may result in faulty braking action.

The #4402 reel hold-down knob (Figure 0) works in the following manner. A removable pin in the bottom surface of the knob engages a corresponding hole in the turntable. A collet grips the turntable shaft when the top of the knob is rotated. Two spring-loaded balls hold the reel to the turntable. A pin in the side of the knob drives the reel. The knob should be positioned on the NARTB reels so that the removable pin engages one of the turntable holes and approximately two thirds of the ball is exposed above the reel. The knob should not be pushed down all the way, but should ride above the turntable. Once the knob is positioned correctly, the NARTB reels may be removed without removing the knobs. When using the knob with the small RMA reels, unscrew the removable pin. The knob is used only to prevent the reel from falling off the turntable, since three keys in the turntable drive and center the reel. Lock the knob to the shaft, avoiding excess pressure on the reel which could distort the reel flanges.

#### 3.2 TAPE THREADING:

Thread the tape as indicated in Figure 11. All new factory wound reels should be unwound and inspected by running through at Fast Forward before using them in the play mode of operation. New tapes are usually looped to the hub in such a manner that the tape will not come free of the reel at the end. This will prevent the Safety Switch (S501) from disengaging the Capstan Idler from the Capstan which results in a flat being worn on the Capstan Idler Wheel. (Any adhesive material accumulation on the reel hub may also keep the tape from coming free at the end of the reel, and should therefore be removed with solvent.)

### 3.3 HALF TRACK OPERATION:

The handling of half track tapes on this machine is accomplished in the following manner. The tape is threaded and operated as described under TAPE THREADING and TAPE MOTION. However, only the upper half of the tape will be used on the half track machine. To utilize the lower half of the tape, the full reel on the Takeup Turntable should be removed, turned over and placed on the Tape Supply Turntable upside down. Place an empty reel on the Takeup Turntable. Repeat the operation as performed on the first track.

### 3.4 POWER:

Power is supplied through Power Switch (S406), which must be turned on to operate the Electronic and Mechanical Assemblies. The Mechanical Assembly and Electronic Assembly are individually fused by the 3 ampere Control Circuit Fuse (F402) and the 1 ampere Electronic Fuse (F401).

### 3.5 SPEED SWITCHES:

There are two switches associated with operating speed. The Tape Speed Switch (S503) determines the speed of the capstan drive motor, and the Equalization Switch (S402) changes the equalization in the amplifiers appropriately.

### 3.6 TAPE MOTION:

The tape motion is controlled by means of four pushbuttons labelled Rewind, Fast Forward, Stop and Play.

1. Play or Record: The tape is set into Play motion at the speed selected by the Tape Speed Switch when the Play Button (S505) is depressed. The tape must be completely stopped before starting in this mode. To change from Play mode to the Record mode with the tape in motion, press the Record Button (S403) on the Electronic Assembly.
2. Stop: To stop the tape while it is moving in any mode, press the Stop Button (S502). The machine will stop automatically if the tape should break or run off either reel.

3. Fast Forward: The Model 350 can be started in Fast Forward or switched to Fast Forward from any of the operating modes by simply depressing the Fast Forward button (S506).
4. Rewind: The Model 350 can be started in Rewind or switched to Rewind from any of the operating modes by simply depressing the Rewind button (S507).

**NOTE:** In using either the Fast Forward or Rewind mode, it is desirable to remove the tape from direct contact with the heads by opening the gate of the Head Assembly. This will reduce wear on the heads and prevent the oxide coating on the tape from depositing on the heads and impairing their performance.

### 3.6.1 EDITING AND CUEING TECHNIQUE:

Indexing the tape as in editing or cueing, or when approaching the end of the reel, is simplified by holding down a combination of buttons. Tape motion can be reduced to a slow creep by holding down the Fast Forward and Rewind buttons simultaneously, and then alternating between the two to control tape direction. When the desired point is reached, the Stop button should be held down until the other buttons are released.

**CAUTION:** Never press the Stop and Play buttons in rapid sequence when the tape is traveling at high speed in the Rewind or Fast Forward modes. This will almost invariably break the tape since it does not allow sufficient time for the tape to stop before the Capstan Idler locks it to the Capstan.

### 3.7 PLAYBACK:

To play back a previously recorded tape, turn the Meter and Output Switch (S405), to the extreme left position designated PLAYBACK-LEVEL. Then start the tape in motion as indicated under PLAY. A Playback Level Control (R430) has been provided on the front panel to adjust the tape level to plus 4 VU output. (Zero on the VU meter.)

### 3.8 RECORD:

To record a new program on previously recorded tape, or on blank tape, turn the Meter and Output Switch (S405) to the second position from the left which is designated RECORD-LEVEL. Turn the Record Level Control (R409) clockwise until the level reads 0 (zero) on the VU Meter on the most intense program peaks. The program can be audibly monitored through either the Phone Jack (J403S), or the Line Out Connector (J404P)

before the tape is in motion. This direct monitor feature allows the program to be set up through the machine without actually recording during the set up period. NOTE: For Correct meter calibration it is important that the Line Out be properly terminated either external to the machine or by the use of the Line Out Termination Switch (S404).

When the program level is properly set, start the tape in motion as indicated under PLAY. Then push the Record Button (S408). (It is desirable that a delay of at least 1/2 second occur before the Record Button is depressed, to allow switching transients to die out before recording is started and prevent permanent magnetization of the Record Head. The Record Indicator (I401) next to the Record Button will now glow and the machine is recording.

It is desirable to check the record bias and erase currents occasionally. In order to do this, turn the Meter and Output Switch (S405), to the positions designated BIAS and ERASE, respectively. The erase is not critical and should read approximately zero on the meter scale. The bias should read between  $-1/2$  and  $+ 1/2$  on the VU scale. The bias is somewhat critical and must be kept within the indicated range in order to record the higher frequencies at 3-3/4 and 7-1/2 inch tape speeds.

The bias is adjusted by means of the Bias Control (R460), located on the electronic chassis. The meter calibration for bias measurement can be checked as indicated in SECTION 5.6.4.

## SECTION 4

### TAPE TRANSPORT MECHANISM

NOTE: The Tape Transport Mechanism described in this section is used in machines of two basic types; those designed for both recording and playback, and those designed for playback only. References to the Record Head and the Record mode should be ignored by owners of machines designed for playback only. All other particular differences between the two types are especially noted as the need arises.

#### 4.1 THE MAJOR ASSEMBLIES

The Tape Transport Mechanism consists of the following major assemblies:

- A. Capstan Drive Motor (B501) - This is an hysteresis synchronous motor whose extended shaft forms the Tape Drive Capstan. The motor has two windings to provide the two tape speeds selected by the Tape Speed Switch, (3503). The Capstan Drive Motor starts operating as soon as the tape is properly threaded.
- B. Takeup and Rewind Assemblies - Each of these assemblies consists of an induction motor (B502 and B503), a turntable mounted directly on the motor shaft, a brake housing assembly, and a flange for mounting the entire unit. These units are not interchangeable, the brake housing on one being the reverse of that on the other. The brakes are solenoid-operated, and are released when the Brake Solenoids (K505 and K506) are energized.
- C. Capstan Idler Assembly-This assembly consists of a swivel-mounted arm and a rubber-tired idler wheel. The action of the Capstan Idler Arm is controlled by the Capstan Solenoid (K501). When the Capstan Solenoid is energized, (it is energized in the Play or Record modes only) the movement of the arm forces the idler wheel against the Capstan, which then drives the tape at a constant speed.
- D. Reel Idler Assembly - This assembly consists of a pulley, a spring-pivot-mounted arm, a tape guide, and a flywheel. The reel idler assembly serves to smooth out transient speed variations in the tape system.

- E. Takeup Tension Arm Assembly - This assembly consists of a spring-pivot-mounted arm, a tape guide, and a tape guide hook. A Drivelock pin in the arm shaft actuates the Safety Switch (3501) which stops the machine if the tape breaks or runs off either reel.
- F. Head Assembly - This assembly consists of three heads (Erase, Record and Playback from left to right when facing the machine) in a die-cast aluminum housing. NOTE: In machines designed for playback only, dummy posts are substituted for the Erase and Record Heads. The front shields for the Record and Playback heads are mounted on the Head Gate. When the gate is opened (during Fast Forward or Rewind operation) a set of Tape Lifting Fingers raises the tape off the head faces to reduce head wear.
- G. Control Circuit Box - The Control Circuit Box houses most of the control circuit, including all relays and tension adjusting resistors. All receptacles for interconnecting cables between the Tape Transport Mechanism and any accessory units with which it may be used are mounted on the front panel of the Control Circuit Box.
- H. Control Circuit Switch Assembly - The switches included in this assembly are as follows: four pushbuttons, for Rewind, Fast Forward, Stop, and Play; two toggle switches, Reel Size and Tape Speed; the Safety Switch, a micro-switch mounted under the top plate near the Takeup Tension Arm shaft. These switches control the operation of the Tape Transport Mechanism in all modes.

#### 4.2 THE TAPE TENSION SYSTEM

The purpose of the Tape Tension System is to provide proper tape tension in all modes of operation. The principles of the system can best be understood by studying the operation of the takeup and rewind motor assemblies.

The Takeup and Rewind Motors are so connected that when power is applied with no tape threaded, the turntables, fixed to their shafts, will rotate in opposite directions. The Tape Supply Turntable, fixed to the Rewind Motor shaft, will rotate clockwise. The Tape Takeup Turntable, fixed to the Takeup Motor shaft, will rotate counterclockwise.



The torque of the motors in the Play and Record modes is adjusted to equality by resistors R503 and R505, the tension adjusting resistors in series with each motor. In Fast Forward, the torque of the Rewind Motor is greatly reduced by insertion of additional resistance (R504) in series with it. In Rewind, R504 is inserted in series with the Takeup Motor. The basic operation of the tape tension system is illustrated in Figures A, B, and C on the following page.

In the Fast Forward mode (Figure A), the Takeup Motor operates at full torque, the Rewind Motor at reduced torque, and the tape is simply pulled from the Tape Supply Reel. Since the torque of the Tape Supply Turntable motor (i. e., the Rewind Motor) is applied in the opposite direction to the table's rotation, the tape is held under continuous tension as it is pulled from the reel.

In the Rewind mode, the operation just described is exactly reversed, as shown in Figure B.

In the Play or Record modes, both motors operate at reduced torque and are effectively isolated from each other by the Tape Drive Capstan and the Capstan Idler between which the tape is clamped, (Figure C). From the point of view of the Tape Supply Turntable, the capstan and idler action exerts sufficient pull on the tape to overcome the opposing torque of the Rewind Motor, which constitutes the hold back tension. From the point of view of the Tape Takeup Turntable, the capstan and idler action is feeding the tape to it. The tape is held under tension here, simply by virtue of the fact that the takeup rate exceeds the feed rate. (A tape loop will be thrown on the right side of the Capstan whenever any malfunction causes the feed rate to exceed the takeup rate.)

In the event that such a tape loop is thrown, or the tape breaks, the Takeup Tension Arm will actuate the Safety Switch (S501) and stop the machine. The Takeup Tension Arm is not, strictly speaking, a part of the tape tension system. Its primary function is to operate the Safety Switch.

The Reel Idler Assembly functions to smooth out any transients in the tension system. For example, in starting the tape in the Play mode, the momentary strain transmitted through the tape to the Tape Supply Turntable when the Capstan Idler forces the tape against the Capstan is extremely high. This impulse could, under some circumstances, stretch or break the tape, or cause the Tape Supply Turntable to overshoot in starting. If the turntable did overshoot in this way, the momentary decrease in hold back tension would be sufficient to start a transient oscillation in the tape tension system. This



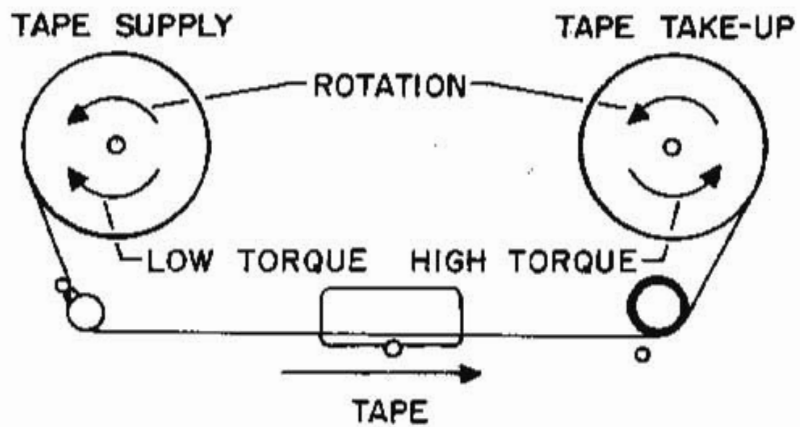

FIGURE A - FAST FORWARD

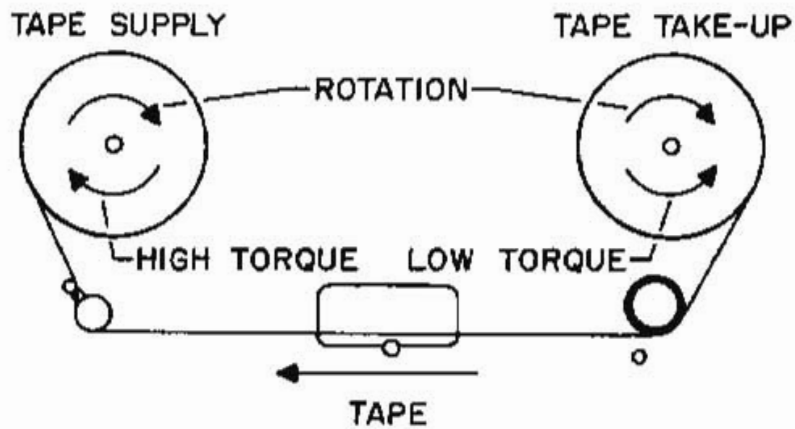

FIGURE B - REWIND

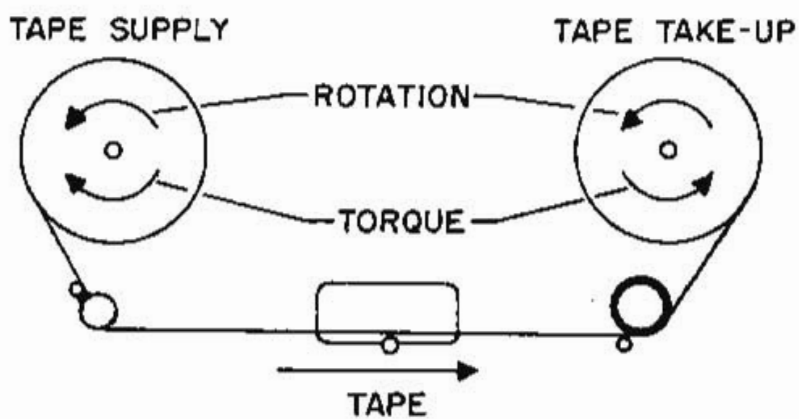

FIGURE C - PLAY OR RECORD

TAPE TENSION SYSTEM

oscillation would be felt in the Head Assembly where it would cause a periodic variation in the distance of the tape from the heads. This variation would be of sufficient magnitude to appear as an undesirable fluctuation in the signal level at the start of recording or reproduction. The Reel Idler Arm serves to absorb most of the starting strain, and effectively prevents or minimizes the type of oscillation just described. The Reel Idler Pulley and Flywheel - provide additional stability to the tape tension system by smoothing out transients in the torque of the Rewind Motor.

#### 4.2.1 BRAKE OPERATION

Smooth brake operation is of primary importance in maintaining proper tape tension while stopping the tape. Since the holdback tension, supplied by the trailing turntable motor torque, is lost as soon as the Stop button is pressed, the maintenance of tape tension then becomes a function of brake operation. The fundamental design consideration in the brake system is that the braking force acting on the turntable from which the tape is being pulled (the trailing turntable) in any of the modes of operation must always exceed the braking force acting on the turntable taking up the tape (the leading turntable) in order to prevent the throwing of tape loops.

Refer to the Takeup Brake Assembly as shown in Figure 12. One end of the brake band is fixed to the brake housing. The other end is linked to the brake lever and is free to move. When the brake solenoid is de-energized, the brake tension spring acting on the brake lever draws the brake band against the brake drum.

If the brake drum is rotating clockwise (as viewed in Figure 12) when the brake band is applied, the frictional force will cause the band to wrap itself more tightly around the brake drum, the linked end of the band moving to the left. Braking force will be increased (i.e., the brake is self-energizing). If the drum is rotating counterclockwise, the process is the reverse. There will be a tendency for the band to pull away from the drum, decreasing the braking force (i.e., the brake is self-relieved). The ratio of the braking force in one direction to the braking force in the other is called the brake differential. The brake differential on this machine is approximately two to one.

The action of the braking system in the various modes of operation is illustrated in Figures E and F, opposite. In terms of the discussion above, note that in all modes, the greater braking force always acts on the trailing turntable. A portion of this increased braking force is exerted on the leading turntable through the tape. Thus the tape remains under tension as the system is brought to a stop.

#### 4.2.2 REEL SIZE SWITCH

Holdback tension is not a constant in any mode of operation. It varies directly as a function of the torque of the trailing turntable motor, and inversely as a function of the effective hub diameter (i.e., hub diameter including the tape wound on the hub) of the trailing reel. That is, for a given torque on the trailing motor, the holdback tension will increase as the effective hub diameter of the trailing reel decreases. Reducing the torque on the trailing turntable motor will decrease the holdback tension.

The holdback tension resistors which adjust the torque of the Takeup and Rewind motors are factory-set for NARTB 10-1/2 inch reels. If the smaller RMA reels are used, the overall increase in the holdback tension must be compensated for in order to prevent tape stretch. This is done by inserting resistor R502 in series with the Takeup and Rewind motors thus reducing the torque of both motors when the RMA reels are used. Insertion is accomplished by the Reel Size Switch, a SPST switch placed across the resistor R502.

#### 4.3 RELAY OPERATION

The operation of the control circuit relays in the various modes can best be understood by referring to the schematic of the mechanical assembly control circuits, Figure 3, while following this discussion. NOTE: All relay contacts in Figure 3 are drawn in their de-energized positions. For convenience in circuit tracing, references to relay contacts in the following description are preceded by the letter D (de-energized) or E (energized), to indicate the position of the contacts in the mode being considered. Each relay sequence described below begins with the tape at a dead stop unless otherwise specified.

##### 4.3.1 PLAY

When the Play button (S505) is pressed, both the Play Relay (K502) and the Capstan Solenoid (K501) are energized. They are held energized through relay contacts EK502-1, DK503-1, DK504-3, and the normally closed

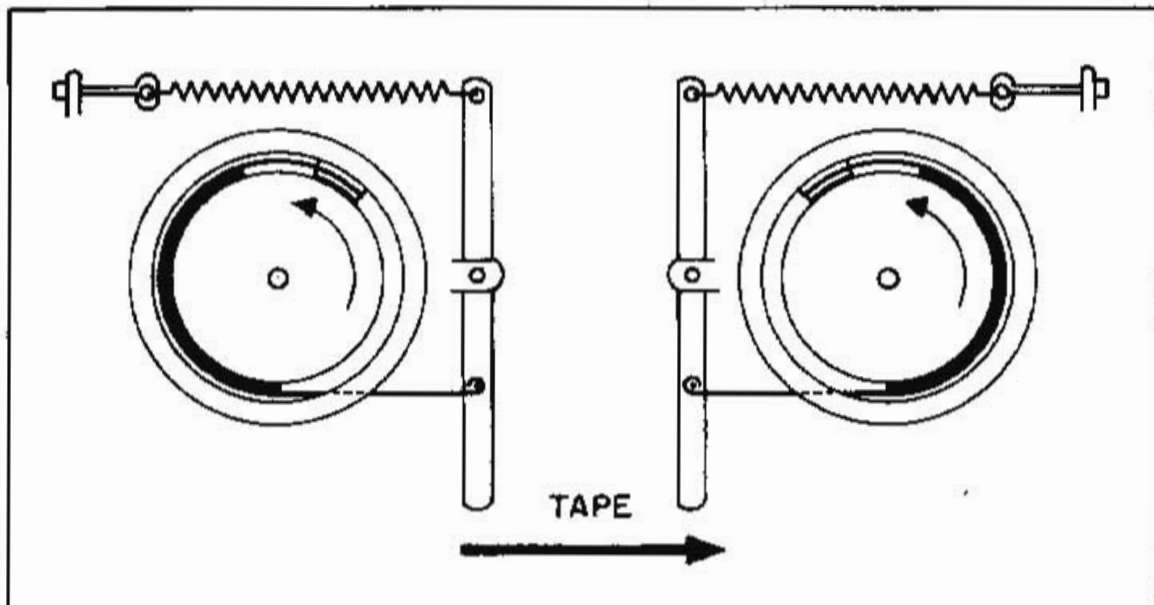

FIGURE D - FAST FORWARD, PLAY & RECORD

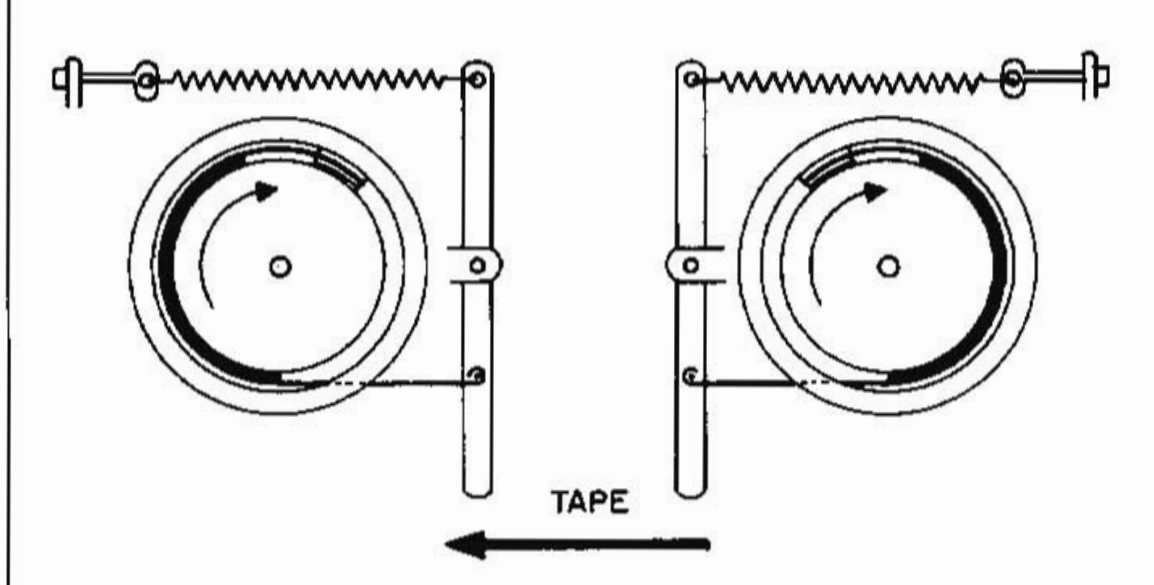

FIGURE E - REWIND

C-6152 350 6-13-53

BRAKE OPERATION

Stop button (S502). The Capstan Idler is forced against the Tape Drive Capstan, and power is applied to the Brake Solenoids (K505 and K506) through contact EK502-3, and to the turntable motors through the contact EK502-2, thus releasing the brakes and starting the turntables. The recorder is now operating in the Play mode at the speed selected by the Tape Speed Switch (S503).

#### 4.3.2 REWIND

When the Rewind button (S507) is pressed, the Rewind Relay, (K504) is energized. This relay is held energized through relay contact EK504-1, DK503-3, and the normally closed Stop button (S502). The Brake Solenoids are held energized through contact EK504-3. Full power is applied to the Rewind Motor through contact EK504-2, and the torque of the Takeup Motor is reduced sufficiently through resistor R504 to provide proper holdback tension. The machine is now in the Rewind mode.

#### 4.3.3 FAST FORWARD

When the Fast Forward button (S506) is pressed, the Fast Forward Relay (K503) is energized, and the Brake Solenoids are energized through contact EK503-3. The Fast Forward Relay is held energized through contacts EK503-1, DK504-3, and the normally closed Stop button (S502). Full power is applied to the Takeup Motor through EK503-2, and the Rewind Motor torque is reduced through R504 to provide proper hold back tension. The machine is now in the Fast Forward mode.

#### 4.3.4 STOP

When the tape is in motion in any mode and the Stop button (S502) is pressed, the Brake Solenoids and all relays are de-energized. The brakes are applied to both turntable motors. The Capstan Drive Motor will continue to operate so long as the tape remains threaded.

#### 4.3.5 SAFETY INTERLOCKS

When the tape is moving in either of the high speed modes (Fast Forward or Rewind) it is not possible to switch to the Play mode without first pushing the Stop button. In Fast Forward, contact EK503-1 interlocks the Play Relay and Capstan Solenoid. In Rewind, EK504-3 is the interlock. CAUTION: If the Stop and Play buttons are pressed in rapid sequence when the tape is in either high speed mode it will almost invariably be broken. Always allow time for the tape to stop completely when switching from the fast modes to Play.

#### 4.4 ROUTINE MAINTENANCE

The routine maintenance program outlined below should be carefully followed if proper performance is expected of the machine at all times. It is recommended that an Operation and Maintenance Log be kept.

##### 4.4.1 CLEANING

The Capstan, the head faces and tape guides should be cleaned daily with ethyl alcohol applied with a soft cloth. **WARNING: DO NOT USE CARBON TETRACHLORIDE TO CLEAN HEADS. IT ACTS AS A SOLVENT ON THE PLYOCND WHICH BINDS THE LAMINATIONS TOGETHER.**

The capstan idler wheel should be cleaned weekly with ethyl alcohol applied with a soft cloth. Great care must be taken to see that oil does not reach the rubber tire. Avoid, as much as possible, touching the tire with the fingers.

The tire will gradually pick up the lubricant with which most tape manufacturers impregnate their tapes. This condition is unavoidable. The lubricant plays an important part in reducing flutter, head wear and tape squeak. It also permits more uniform head contact, and therefore reduces high frequency amplitude variation.

In general, failure to keep the idler wheel tire free of tape lubricant or any other oil by weekly cleaning will eventually result in loss of positive drive at the Capstan - particularly toward the end of a reel when holdback tension is highest.

##### 4.4.2 LUBRICATION

The following parts of the Tape Transport Mechanism require lubrication every three months, or after every thousand hours of operation, whichever occurs first.

A. Capstan Drive Motor. The upper sleeve bearing of the Capstan Drive Motor should be lubricated with one of the following recommended oils or its equivalent:

Gulf Oil & Refining Company - (Gulcrest A)  
Standard Oil Co. of Indiana - (Stanoil #18 or #25)  
Socony Vacuum Oil Co. - Gargoyle DTE Light

For proper lubrication, the Drive Motor should be removed. To dismount the motor, remove the four screws that hold it to the top plate and unplug the motor connector (J504F) from its socket (J504C). (One of the motor mounting screws is below the Capstan Idler. For access, hold the idler back.) The oil hole will be found in either the top or the side of the motor end bell, depending upon the motor manufacturer. Lubricate with ten drops of one of the recommended lubricants and replace the motor. After replacement, check the capstan idler pressure and if necessary readjust as indicated in 4.3.2.

E. Capstan Idler. Remove the dust cap on the wheel hub by prying up gently. Lubricate by saturating the felt washer with no more than 6 drops of SAE 20 oil. WARNING: Do not over-lubricate or the wheel will throw oil in operation. Should oil spill on the rubber tire, clean immediately with ethyl alcohol.

NOTE: The Reel Idler Assembly, the Takeup Tension Arm Assembly and the Takeup and Rewind Motors contain ball bearings, and require no lubrication.

#### 4.4.3 HEAD DEMAGNETIZATION

Occasionally, the heads may become permanently magnetized through an electrical fault in the amplifiers, improper use of the machine, or by coming in contact with a magnetized object. Magnetized heads will cause an increase of 5 to 15 db in noise level, and may ruin good tapes by partially erasing high frequencies. The full dynamic range of the machine cannot be realized if the heads are magnetized.

Any phenomena that tend to put a large unbalanced pulse through the record head will magnetize it. If the following precautions are observed, no difficulty should be experienced.

- A. Do not remove any tube from the record amplifier while the machine is recording.
- B. Do not connect or disconnect input leads or head leads while recording.
- C. When putting the machine in the Record mode, wait a half second between the pushing of the Play and the Record buttons to allow motor and solenoid switching transients to die out before the Record Head is connected, in order to prevent permanent magnetization of the head.



D. Do not saturate the record amplifier with abnormally high input signals. Such signals would be 10 db greater than tape saturation or approximately 30 db greater than normal operating level.

E. Do not test continuity of the heads with an ohm meter.

Should the heads become magnetized, they can be demagnetized readily with an AMFEM Head Demagnetizer (Catalog 704). The following demagnetization procedure should be performed: Throw the Power switch OFF. Plug the Demagnetizer into a 117 volt AC source. Bring the tips of the demagnetizer in close proximity to, but preferably not in contact with, the head core stack. Run the tips of the demagnetizer up and down the entire length of the core stack (the tips should straddle the gap) three or four times. Remove the demagnetizer very slowly allowing the influence of its AC field to die off gradually. This operation need be performed only on the Record and Playback heads, as the Erase head will demagnetize itself. In the event demagnetization is not effected, repeat the process several times.

Should the Capstan or tape guides become magnetized through contact with some magnetized object, a few passes up and down their length with the head demagnetizer and then slow withdrawal should suffice to demagnetize them.

#### 4.5 ADJUSTMENTS

The mechanical assembly is shipped from the factory with all adjustments set for correct performance. It should not be necessary to change any adjustment before putting the machine into service, unless shipping damage has occurred. In the course of wear in normal service, or in the event of component failure, and replacement of parts, some readjustments may be necessary. The recommended procedures for making such adjustments are detailed below. The locations of all adjustment points are shown in the figures at the rear of this book.

##### 4.5.1 TAKEUP AND REWIND TENSION

Takeup and rewind tensions are adjusted by the slides on resistors R503 and R505. The torque of both the rewind and takeup motors must be adjusted to six ounces at NART's Reel hub diameter. This is done as follows:



A. Place an empty 10-1/2 inch NARTB reel on the Tape Supply Turntable.

B. Take a piece of string about thirty inches long, and tie a small loop at each end.

C. Attach one loop to the tape anchor on the reel hub, and the other loop to a spring scale (0 to 10 oz. preferred).

D. Hold the Safety Switch closed by taping the Takeup Tension Arm in the switch-on position with a piece of scotch tape or masking tape.

E. Press the Play button and read the pull as the string is wound onto the hub. It is advisable to "follow" the string in slowly, taking the reading while the turntable is in steady motion. (The static pull of the turntable may produce a reading slightly higher than the steady motion reading.)  
NOTE: Most spring scales, when held horizontally, will show a zero reading different from the normal scale zero. Allowance for this error should be made when taking readings.

F. Adjust R505 for a six ounce scale reading.

G. Repeat the entire procedure on the Takeup Turntable, adjusting R503 for six ounces.

#### 4.5.2 BRAKE TENSION

Brake tension is adjusted with no power applied to the machine. Adjustments are made at the two points shown in Figure 12. The procedure is as follows:

A. Place an empty 10-1/2 inch NARTB reel on the Tape Supply Turntable.

B. Tie a loop at each end of a piece of string about thirty inches long.

C. Attach one loop to the tape anchor on the reel hub. Wind the string on by turning the reel clockwise by hand.

D. Attach the loop in the free end of the string to a spring scale, and pull. (The turntable will rotate counterclockwise.) Take a reading only when the turntable is in steady motion, as the force required to overcome the static friction will produce an excessively high initial reading.

E. Adjust the rewind motor brake for a reading of approximately 14 ounces.

F. Now wind the string on the hub by rotating the reel counterclockwise; pull, and take a reading. (The turntable will rotate clockwise.) The reading should be approximately 7 ounces.

G. Repeat the entire process on the takeup turntable, this time adjusting for approximately 14 ounces when the table is rotating clockwise and approximately 7 ounces counterclockwise.

NOTE: After long usage, the graphited-felt linings of the brakes will begin to glaze, and the brakes may exhibit some tendency to grab. This condition may be relieved by periodic readjustment of brake tensions, but eventually the brake linings will have to be reconditioned or replaced, as described in the Section 4.6.2.

#### 4.5.3 CAPSTAN IDLER PRESSURE

The Capstan Idler is forced against the Capstan by the action of the Capstan Solenoid (K501). Idler pressure is supplied by the Capstan Idler Pressure Spring, and is adjusted by a lock nut on the Capstan Solenoid spade bolt. (See Figure 12.) Little or no pressure is supplied by the spring if the Capstan Solenoid is not bottomed. Tightening the lock nut increases idler pressure until a point is reached where the solenoid will not bottom. At this point, idler pressure drops to a value which is inadequate to permit the Capstan to drive the tape, and slippage will occur unless the nut is backed off. Excessive pressure should also be avoided as it throws an unnecessary load on the upper sleeve bearing of the Drive Motor. The recommended procedure for adjusting idler pressure is as follows:

A. Hold the safety switch on by taping the Takeup Tension Arm in the switch-on position with a piece of scotch tape or masking tape.

D. Press the Play button, and check to see that the Capstan Solenoid is bottomed. (The Capstan Idler can be pushed off the Capstan easily by pushing on the idler arm, if the solenoid is not bottomed.) If necessary, back off the lock nut until the solenoid does bottom. (See NOTE below.)

C. Readjust the lock nut until the Capstan Idler is just touching the Capstan when the solenoid is bottomed (the point at which one finger held lightly on the capstan idler hub will keep it from rotating).

D. Tighten the lock nut 2-1/4 turns.

E. Press the Stop button, then press the Play button and check to be sure that the solenoid will bottom after the last adjustment. If not, then either the solenoid or linkage is defective.

If properly adjusted as outlined above, sufficient capstan idler pressure exists under all operating conditions to prevent tape slippage, unless the idler or the Capstan should become contaminated with oil or foreign matter.

NOTE: In the course of normal operation in the play or record modes, the temperature of the Capstan Solenoid will rise, and its DC resistance will increase. Therefore, the minimum line voltage required to bottom the solenoid when it is hot will be greater than that required when it is cold. If the machine is operating on unusually low line voltage, sometimes encountered in areas where regulation is poor, the solenoid may fail to bottom after it has reached normal operating temperature. It is advisable, therefore, to allow the machine to operate in the Play mode for about half an hour before making any necessary solenoid adjustments. This will allow the widest margin of safety with respect to line voltage variations. (The solenoid is factory-adjusted to bottom at 90 line volts cold and 105 line volts hot.)

#### 4.6 REPLACEMENT OF PARTS

All sub-assemblies of the Tape Transport Mechanism can be easily dismantled with the use of a screwdriver and a few small socket-head screw keys. CAUTION: IT IS INADVISABLE TO ATTEMPT COMPLETE DISASSEMBLY OF ANY OF THE SUB-ASSEMBLIES. THE LIST OF INDIVIDUALLY REPLACEABLE PARTS UNDER EACH ASSEMBLY LISTING IN THIS PARTS LIST SHOULD BE USED AS A GUIDE IN DISASSEMBLY WORK.

REPLACEMENT OF PARTS OTHER THAN THOSE LISTED CALLS FOR PRECISION WORK WHICH SHOULD NOT BE ATTEMPTED IN THE FIELD. ASSEMBLIES WITH DEFECTS IN PARTS OTHER THAN THOSE LISTED AS REPLACEABLE SHOULD BE RETURNED TO THE FACTORY FOR REPAIR OR REPLACEMENT.

#### 4.6.1 PACKING PRECAUTIONS FOR MOTORS

In packing motors for return to the factory, particular care should be taken in order to avoid the bending of their shafts in transit. When packing a Capstan Drivemotor, always remove the fan and flywheel from the motor shaft. Retain the fan and send the flywheel with the motor.

#### 4.6.2 BRAKE RECONDITIONING AND REPLACEMENT

Brake linings may be reconditioned in place by the following procedure: Mix one level tablespoon of graphite with 8 ounces of carbon tetrachloride. Apply to the brake linings with an oil can. (Be sure the can is free of all traces of oil.) After re-graphiting, the turntable motors should be run for ten minutes with the brakes on in order to wear in the graphite. This can be accomplished either by disconnecting the brake solenoids temporarily, or by removing one of the clevis pins in the brake linkage to prevent the brakes from being released when the solenoids are energized.

If the brake linings are too badly worn to respond to this reconditioning procedure, the brake band assemblies should be replaced as follows, referring to Figure 12:

- A. Dismount the Brake Housing Assembly by removing the screws that hold it to the motor, taking care not to drop or lose the spacers under the housing.
- B. Unhook the Brake Tension Spring. Loosen, but do not remove, the two socket-head screws in the Brake Band Link by inserting a socket-head screw key (i.e. an Allen wrench) between the two Brake Solenoid Links.
- C. Pull the Solenoid Plunger out of the Solenoid, and the Brake Band will come free of the Link. Note that this end of the band is slotted.

D. Remove the two screws that hold the other end of the Brake Band to the housing. Note that three clamping elements are involved: the clamp, and two spring-steel leaves, and that the assembly order, from the housing wall out is brake band, long leaf, short leaf, clamp.

E. Immediately before installing the new brake band assembly, it should be pressed flat between two boards in a vise in order to compress the felt lining. If this is not done the lining will be too thick to permit free rotation of the brake drum after installation, and will result in dragging brakes and improper brake differential. Once the band is installed, the felt will no longer swell, as it does relatively quickly when the bands are not bent in their normal curve.

F. To install the new brake, insert it through the hole in the housing, making sure the lining faces in toward the center, and secure it to the housing.

G. Insert the Solenoid Plunger and slip the slotted end of the Brake Band back between the Brake Band Link and Clamp. **DO NOT TIGHTEN THE SCREWS ON THE LINK.**

H. Re-mount the Brake Housing Assembly on the motor. (Be sure to install the spacers.)

I. Push the Solenoid Plunger down until it bottoms. Adjust the depth of insertion of the Brake Band between the Link and Clamp so that the Brake Drum rotates freely with no drag; then, tighten the screws. **CAUTION: If the band is set too far forward in the link, it will buckle slightly when the Solenoid Plunger is bottomed by hand. If this condition exists the plunger may not bottom when the solenoid is energized.**

J. Re-install the Brake Tension Spring.

K. Run the brakes in for ten minutes as described in the re-conditioning procedure above, and then adjust the brake tension as described in Section 4.3.2.

## SECTION 5

### ELECTRONIC ASSEMBLY

The Electronic Assembly consists of a Record Amplifier, a Playback Amplifier and a Bias and Erase Oscillator on one chassis. The Power Supply is mounted on a separate chassis.

#### 5.1 Record Amplifier

The Record Amplifier consists of four stages; a high-gain pentode pre-amplifier for microphone and balanced bridge inputs (V401, 12SJ7), two triode-connected-pentode amplifiers (V402, V403, two 12SJ7), and a constant-current triode output stage (V404, 6C5/6J5).

One of three available input circuits can be selected by the Input Transfer switch (S401). When S401 is in the UNBALANCED BRIDGE position, the input transformer (T401) and the input pre-amplifier (V401) are bypassed, and the signal is fed to the grid of V402 through the Record Level Control (R409).

Separate high frequency pre-emphasis for each speed is provided by the Record Equalizers (C406 or C407 and R413) between V402 and V403, and the LC combination in the cathode return of V404. Equalization is changed by the Equalization Switch (S402).

The output of the constant current amplifier (V404) is fed to the Record Head through the coupling condenser (C412). The Noise Balance Bridge (R422, R423, R424, R425) serves to counterbalance any leakage current from C412 or any asymmetry in the Bias Oscillator (V408) output, either of which would tend to magnetize the Record Head permanently and result in an increase of 5 to 10 db in noise level, and the introduction of second harmonic distortion.

When the Record button (S403) is pressed, the Record Relay (K401) is energized through contact K502-1 of the Play Relay (in its energized position), K503-1 of the Fast Forward Relay (de-energized), and K504-3 of the Rewind Relay (de-energized). The Record Relay therefore cannot be energized unless the machine is in the PLAY mode. (See Figures 1 or 2, and 3.)

## 5.2 Playback Amplifier

The Playback Amplifier is a three-stage pentode amplifier which provides a +4 VU 600 ohm output at the Line Out Connector (J404P). The feedback loop of the first stage (V405) includes the Playback Equalizer (R435 and C417) which provide a suitable RC for Playback de-emphasis. A feedback loop around the last two stages (V406, V407) serves to minimize distortion.

## 5.3 Bias and Erase Oscillator

The Bias and Erase Oscillator (V408) is a conventional push-pull triode oscillator which provides a 100 KC signal to the Erase and Record Heads.

## 5.4 VU Meter and Monitoring

Visual and audible monitoring checks are provided by the VU meter (M401) and the Phone Jack (J403S). With the Meter and Output Switch (S405) in the Erase position, the VU is connected across R458 and indicates erase current. With S405 in the Bias position, the VU is across R459 and indicates Bias current. The VU is across the Playback Amplifier output in both the Playback and Record positions of S405. In the Playback position, the VU monitors the complete playback circuit from the Playback Head to the Line Out (J404P). In the Record position, the last two stages of the Playback Amplifier are disconnected from the first stage and are fed by the output of the first two stages of the Record Amplifier (picked off R423, the Record Calibration Control).

## 5.5 Power Supply

The Power Supply (Figure 4) provides 6.3 volt AC heater power, 12.6 volt DC heater power (through a full wave selenium rectifier, SR601) and the plate supply through a 5Y3G Full Wave Rectifier.

## 5.6 Electronic Alignment

Alignment consists of making all adjustments necessary for proper electronic performance. A recorder "out of alignment" may be characterized by poor frequency response, high noise, low output, high distortion, or a combination of these faults. All Ampex recorders are correctly aligned at the factory just before shipment. It should not be necessary to realign the recorder on arrival. Should there be a doubt at any time concerning the



condition of the recorder, it is suggested that a rapid overall performance check be made as described in Section 2. Realignment is called for only if performance does not fall within the limits given in Specifications.

The following two sections should be thoroughly absorbed before going on to the details of alignment procedure.

#### 5.6.1 Alignment and Test Equipment Requirements

The following list covers the minimum equipment requirements for proper alignment and testing.

- A. Audio Oscillator - Hewlett-Packard Model 200C or equivalent.
- B. Vacuum Tube Voltmeter - Hewlett-Packard Model 400C or equivalent.
- C. Ampex Alignment Tape  
  
For 3-3/4 - 7-1/2 inch machines - Ampex Catalog #5563  
For 7-1/2 - 15 inch machines - Ampex Catalog #4494  
Both of these tapes are recorded at 10 db below Operating Level. The Catalog #5563 tape is recorded at 7-1/2 inches per second, the #4494 at 15 inches per second. Each tape contains voice announcements for the following tone sequence: playback head azimuth check tone, reference tone for playback level adjustment, tone series for playback response check.
- D. Ampex Head Demagnetizer - Ampex Catalog #704
- E. High Impedance Headphones
- F. 1/4" Hexagonal Socket Wrench

#### 5.6.2 General Precautions

It is always advisable to demagnetize the record and playback heads BEFORE putting an alignment tape on the machine. Magnetization of the heads will cause partial erasure of the high frequencies on the tape and make it useless as a standard. Demagnetization procedure is given in Section 4.4.3.



The amplifier output must always be terminated in 600 ohms when testing or aligning. Either put the LINE TERMINATION switch (S404) in the CN position or terminate the LINE OUT externally with a 600 ohm resistor.

It is not necessary to dismount the Electronic Assembly from the console or case for most alignment procedures. The procedures that require bench adjustments are specially noted as they appear. CAUTION: There are a few distinct differences between adjusting a 3 3/4 - 7 1/2 inch machine and a 7 1/2 - 15 inch machine. Read the procedures carefully where these differences are indicated.

A vacuum tube voltmeter is not strictly necessary in most of the procedures outlined, as the internal VU meter serves adequately. Only in cases where levels fall in the less sensitive ranges of the VU meter is a VTVM called for. Corresponding readings of VU meter and VTVM are given wherever applicable.

### 5.6.3 Playback Circuit Alignment

Playback circuit alignment consists of the following:

- A. Playback Head Alignment (Steps 1, 2, 3, 4, 5)
- B. Playback Level Setting (Step 6)
- C. Playback Response Check (Step 7)
- D. Playback Equalization (Step 8)

#### A. Playback Head Alignment

1. Throw the Line Termination Switch (S404) ON. Throw the Tape Speed Switch (S503) and the Equalization Switch (S402) to HIGH. Turn the Meter and Output Switch (S405) to PLAYBACK-LEVEL. Set the Playback Level Control (R438) at mid-scale.
2. Connect a VTVM to LINE OUT (J404P), strapping Pins 1 and 2 together. Connect high impedance phones to Phone Jack (J403S).

3. Remove the two screws from the top of the Head Housing Cover, and pull the cover gently up and back to remove it. (The heads, from left to right, when facing the machine, are; Erase, Record, and Playback). The left-hand elastic stop nut on top of the Record and Playback heads is the azimuth adjust. CAUTION: NEVER ATTEMPT TO ADJUST ANY OTHER NUT OR SCREW ON THESE HEADS.
4. Thread the appropriate alignment tape on the machine (see Section 5.6.1 C), and press the Play button. The first tone on the tape is for Playback Head alignment.
5. Using a 1/4 inch hexagonal socket wrench, adjust the left-hand elastic stop nut on top of the Playback Head for maximum output as seen on the VU or the VTVM.

#### B. Playback Level Adjustment

6. The second tone on the tape is for Playback Level adjustment. Adjust the Playback Level Control (R438) for a reading of -10 on the VU (-6DBM on the VTVM). CAUTION: THIS SETTING MUST BE RETAINED UNTIL THE RECORD LEVEL METER CALIBRATION HAS BEEN ADJUSTED AS DESCRIBED LATER. IT IS SUGGESTED THAT THE SETTING BE MARKED BY A PENCIL LINE ON THE FACE PLATE.

#### C. Playback Response Check

7. The next series of tones is for checking the frequency response of the Playback Head and Amplifier. If the playback circuit is properly aligned, the response will meet specifications at both speeds available on the machine. If the response does not meet specifications, one of the following is indicated:
  - (a) Worn or otherwise faulty Playback Head.
  - (b) Faulty alignment tape. (High frequencies partially erased by passing over magnetized heads.)
  - (c) Playback Amplifier improperly equalized. (See Step 8, which follows)

#### D. Playback Equalization

3. Equalization setting will usually be found most convenient as a bench procedure. The curves to which the machines are set at the factory are shown in Figure 6. Note that the 7 1/2" and 15" Playback curves are identical. The 3 3/4" curve differs, but is not adjustable. Therefore, Playback equalization need be set only at the 7 1/2" speed on any machine. With the Equalization Switch set for the 7 1/2" speed, connect an audio oscillator and VTVM as shown in Figure 6, and adjust the Playback Equalizer (R435) to give the frequency response of the 7 1/2" - 15" curve. Deviation from this curve is not recommended. CAUTION: IF IT HAS BEEN NECESSARY TO ADJUST THE PLAYBACK EQUALIZATION, AS DESCRIBED ABOVE, GO BACK AND REPEAT STEP 6 BEFORE PROCEEDING ANY FURTHER.

#### 5.6.4 Erase and Record Circuit Alignment

Erase and Record Circuit Alignment consists of the following:

- A. Erase Adjustment (Steps 1, 2)
- B. Bias Adjustment (Steps 3, 4, 5, 6)
- C. Bias Meter Calibration (Step 7)
- D. Record Level Meter Calibration (Steps 8, 9)
- E. Record Head Alignment (Steps 10, 11)
- F. Record Equalization and Response Check (Steps 12, 13, 14, 15)
  - 15" Equalization (Steps 12, 13)
  - 7 1/2" Equalization (Steps 12, 14)
  - 3 3/4" Equalization (Steps 12, 15)
- G. Noise Balance Adjustment (Step 16)

#### A. Erase Adjustment

1. Thread a new blank tape on the machine.
2. Turn the Meter and Output Switch (S405) to the ERASE position. Put the machine in the Record mode and read the erase current indication on the VU meter. The reading should be approximately zero. (Since line voltage has some effect on erase current, variations of +1 db in the meter reading may be expected. Do not readjust the Erase Trimmer if the reading falls within this range.) To adjust erase current, back off the Erase Trimmer (C43C) to minimum capacity (clockwise), and then increase the capacity until the VU meter reads approximately zero. CAUTION: THE ERASE CURRENT ADJUSTMENT HAS A DIRECT EFFECT ON BIAS CURRENT AND SHOULD NOT BE CHANGED AFTER THE BIAS ADJUSTMENT HAS BEEN MADE AS DESCRIBED BELOW. THE BIAS ADJUSTMENT WILL NOT AFFECT THE ERASE CURRENT.

#### B. Bias Adjustment

3. Turn the Meter and Output Switch (S405) to the PLAYBACK-LEVEL position. Turn the Input Transfer Switch (S401) to the UNBALANCED BRIDGE position. Throw the Tape Speed Switch (S503) and Equalization Switch (S402) to HIGH.
4. Connect an audio oscillator to the LINE IN (J401S) strapping Pins 1 and 2 together.
5. For a 3 3/4" - 7 1/2" machine, set the audio oscillator frequency at 500 cycles. For a 7 1/2" - 15" machine set the oscillator at 1000 cycles. (These are the optimum frequencies for adjusting Record Bias on the two machines. The adjustment is made at the higher of the two speeds available on any machine, and serves for both speeds.) Put the machine in the Record mode, and adjust the Record Level Control (R409) for a reading of approximately zero on the VU, (approximately +4 DBM on the VTVM).

6. Adjust the Bias Control (R469) for maximum output as seen on the VU or VTVM. (It is desirable to be within at least 1/2 db of the maximum efficiency point in order to achieve wide frequency range recording at the lower of the two available speeds.)

#### C. Bias Meter Calibration

7. With the machine still operating as described under Bias Adjustment, above, turn the Meter and Output Switch to the RECORD-BIAS position. Adjust the slide on the Bias Meter Calibration resistor (R459) for a zero reading on the VU meter, (+4 DBM on the VTVM).

#### D. Record Level Meter Calibration

8. With the machine operating as described in the last step, turn the Meter and Output Switch to the PLAYBACK-LEVEL position, and re-set the audio oscillator to 250 cycles. Set the Record Level Control (R409) for a reading of zero on the VU (+4 DBM on the VTVM). BE SURE THE PLAYBACK LEVEL CONTROL IS STILL SET AS DESCRIBED IN SECTION 5.6.3 STEP 6.
9. Turn the Meter and Output Switch to the RECORD-LEVEL position, and adjust the Record Level Meter Calibration resistor (R428) for a reading of zero on the VU (+4 DBM on the VTVM).

#### E. Record Head Alignment

10. Set the audio oscillator at 15,000 cycles, (10,000 cycles for 3 3/4" - 7 1/2" machines) and be sure the Tape Speed and Equalization switches are on HIGH. Turn the Meter and Output Switch to the RECORD-LEVEL position. Set the Record Level Control (R409) for a reading of -10 on the VU (-6 DBM on the VTVM). (For 3 3/4" - 7 1/2" machines, set for -16 DBM on the VTVM.)
11. Turn the Meter and Output Switch to the PLAYBACK-LEVEL position. With the machine in the Record mode, adjust the left-hand elastic stop nut on top of the Record Head for maximum output as seen on the VU or VTVM. Several peaks may be noted. Always choose the peak of greatest amplitude. NOTE: The Playback Level Control ( R 438 ) maybe set for increased gain so that

this and the following adjustments may be made in a more sensitive meter range. CAUTION: WHEN REPLACING THE HEAD HOUSING COVER, DO NOT TIGHTEN DOWN TOO HARD ON THE SCREWS, OR THE HEAD ALIGNMENT MAY BE DISTURBED BY BOWING OF THE HEAD MOUNTING PLATE.

#### F. Record Equalization and Response Check

12. Unlike Playback Amplifier Equalization, Record Amplifier Equalization must be adjusted at both speeds available on any machine. The curves shown in Figure 7 are those to which the machines have been set at the factory, using a typical professional quality tape. If the factory settings do not produce a flat response on the tape of your choice, do not hesitate to readjust the equalization (bias must be readjusted as well). The following procedure will produce a flat overall response for any professional quality tape.

##### 15" Equalization

13. Set the Tape Speed Switch and Equalization Switch for 15" speed. Set the audio oscillator at 250 cycles. Turn the Meter and Output Switch to the RECORD-LEVEL position and set the Record Level Control (R409) for a reading of -10 on the VU (-6 DBM on the VTVM). Switch to the PLAYBACK-LEVEL position. (The Playback Level Control, (R430) may be set for increased gain if desired.) Re-set the audio oscillator to 8,000 cycles, put the machine in the Record mode, and adjust the appropriate Record Equalizer for a reading of -10 on the VU (-6 DBM on the VTVM). Frequency response should now be within specifications, and can be checked by sweeping the oscillator through the range specified in Section 1.

#### 7-1/2" Equalization

14. Set the Tape Speed Switch and Equalization Switch for 7-1/2" speed. Set the audio oscillator to 250 cycles. Turn the Meter and Output Switch to the RECORD-LEVEL position and set the Record Level Control for a reading of -16 DBM on the VTVM. Switch to the PLAYBACK-LEVEL position. (The Playback Level Control may be set for increased gain if desired.) Re-set the audio oscillator to 8,000 cycles, put the machine in the Record mode, and adjust the appropriate Record Equalizer for a reading of -16 DBM on the VTVM. Frequency response should now be within specifications, and can be checked by sweeping the oscillator through the range specified in Section 1.

#### 3-3/4" Equalization

15. Set the Tape Speed Switch and Equalization Switch for 3-3/4" speed. Set the audio oscillator to 250 cycles. Turn the Meter and Output Switch to the RECORD-LEVEL position and set the Record Level Control for a reading of -16 DBM on the VTVM. Switch to the PLAYBACK-LEVEL position. (The Playback Level Control may be set for increased gain if desired.) Re-set the audio oscillator to 6,500 cycles, put the machine in the Record mode, and adjust the appropriate Record Equalizer for a reading of -16 DBM on the VTVM. Frequency response should now be within specifications, and can be checked by sweeping the oscillator through the range specified in Section 1.

#### G. Noise Balance Adjustment

16. The Noise Balance Control (R424) should never be touched unless the heads have first been thoroughly demagnetized as described in Section 4.4.3. If a crackling noise is still heard in the output after head demagnetization, connect a 1 MFD condenser across the LINE OUT and adjust R424 for minimum Record noise as read on a sensitive meter or heard in a loudspeaker connected to the output through a power amplifier.



## SECTION 6

### PARTS LIST

This Parts List provides all information necessary for ordering complete equipment or any replacement part. The list is divided as follows:

- 6.1 Complete Equipment
- 6.2 Tape Transport Mechanism
- 6.3 Electronic Assembly
- 6.4 Power Supply
- 6.5 Miscellaneous

Do not use schematic reference numbers when ordering parts. The Ampex Catalog Numbers are the exact designations for all parts used in Ampex equipment.

**ALWAYS INCLUDE THE FOLLOWING INFORMATION WHEN ORDERING PARTS:**

- Model Number of Machine
- Serial Number of Machine
- Ampex Catalog Number of Part
- Description of Part

Example: 475-17 Half Track Head Assembly for Model 350,  
Serial #53F147.

**IMPORTANT:** Read Section 4.6 on Replacement of Parts before disassembling any unit requiring a replacement part.

6.1 MODEL 350 (Complete Equipment)

Ampex  
Catalog  
Number

Rack Mount, 7-1/2" - 15", Full Track, 60 Cycle Power	5717
Rack Mount, 7-1/2" - 15", Half Track, 60 Cycle Power	5717-1
Rack Mount, 7-1/2" - 15", Full Track, 50 Cycle Power	5717-2
Rack Mount, 7-1/2" - 15", Half Track, 50 Cycle Power	5717-3
Rack Mount, 3-3/4" - 7-1/2", Full Track, 60 Cycle Power	5720
Rack Mount, 3-3/4" - 7-1/2", Half Track, 60 Cycle Power	5720-1
Rack Mount, 3-3/4" - 7-1/2", Full Track, 50 Cycle Power	5720-2
Rack Mount, 3-3/4" - 7-1/2", Half Track, 50 Cycle Power	5720-3
Console, 7-1/2" - 15", Full Track, 60 Cycle Power	5718
Console, 7-1/2" - 15", Half Track, 60 Cycle Power	5718-1
Console, 7-1/2" - 15", Full Track, 50 Cycle Power	5718-2
Console, 7-1/2" - 15", Half Track, 50 Cycle Power	5718-3
Console, 3-3/4" - 7-1/2", Full Track, 60 Cycle Power	5721
Console, 3-3/4" - 7-1/2", Half Track, 60 Cycle Power	5721-1
Console, 3-3/4" - 7-1/2", Full Track, 50 Cycle Power	5721-2
Console, 3-3/4" - 7-1/2", Half Track, 50 Cycle Power	5721-3
2 Case Portable, 7-1/2" - 15", Full Track, 60 Cycle Power	5719
2 Case Portable, 7-1/2" - 15", Half Track, 60 Cycle Power	5719-1
2 Case Portable, 7-1/2" - 15", Full Track, 50 Cycle Power	5719-2
2 Case Portable, 7-1/2" - 15", Half Track, 50 Cycle Power	5719-3
2 Case Portable, 3-3/4" - 7-1/2", Full Track, 60 Cycle Power	5722
2 Case Portable, 3-3/4" - 7-1/2", Half Track, 60 Cycle Power	5722-1
2 Case Portable, 3-3/4" - 7-1/2", Full Track, 50 Cycle Power	5722-2
2 Case Portable, 3-3/4" - 7-1/2", Half Track, 50 Cycle Power	5722-3

Reference Number	Description	Ampex Catalog Number
<b>6.2 <u>TAPE TRANSPORT MECHANISM</u> (Catalog #5700, -1, -2, -3)</b>		
<u>Drive Motor Assembly (Complete) See Note 1</u>		
	7-1/2 - 15 i.p.s. 60 Cycle Motor	6150
	7-1/2 - 15 i.p.s. 50 Cycle Motor	6151
	3-3/4 - 7-1/2 i.p.s. 60 Cycle Motor	5585
	3-3/4 - 7-1/2 i.p.s. 50 Cycle Motor	5778
	<u>Takeup Assembly (Complete)</u>	<b>9451</b>
	Takeup Motor Assembly	6768
	Includes Motor, Mounting Flange, Brake Drum, and Turntable with Pad.	
	<u>Individually Replaceable Parts</u>	
	Brake Housing	317
	Brake Band Assembly (band & lining)	328
	Brake Band Leaves	720-1 & 720-2
K-505	Brake Solenoid	337
	Brake Tension Spring	322
	Turntable Pad	958
	<u>Rewind Assembly (Complete)</u>	<b>9452</b>
	Rewind Motor Assembly	6768
	Includes Motor, Mounting Flange, Brake Drum, and Turntable with Pad.	
	<u>Individually Replaceable Parts</u>	
	Brake Housing	316
	Brake Band Assembly (band & lining)	328
	Brake Band Leaves	720-1 & 720-2

Note 1 - Replacement assemblies include one of the four motors listed, a motor condenser, flywheel, plug, and mounting adaptor (required for Bodine motors only). Use the motor catalog number only when ordering the complete assembly.

Reference Number	Description	Ampex Catalog number
K-506	Brake Solenoid	337
	Brake Tension Spring	322
	Turntable Pad	958
	<u>Takeup Tension Arm Assembly (Complete)</u>	425
	<u>Individually Replaceable Parts</u>	
	Takeup Tension Arm Spring	422
	Tape Guide	675
	Tape Guide Hook	355
	<u>Reel Idler Assembly (Complete)</u> (Does not include Flywheel)	
	For 7-1/2" - 15" Machine	4459
	For 3-3/4" - 7-1/2" Machine	4459-3
	<u>Individually Replaceable Parts</u>	
	Tape Guide	257
	<u>Reel Idler Flywheel</u>	636
	<u>Capstan Idler (Reel Assembly only)</u>	500
	Capstan Idler Arm	372
	Capstan Idler Arm Bushing	5755
	Capstan Dust Cap	2607
	Capstan Dust Cap Felt Washer	3583
	Capstan Dust Cap Retaining Ring	OR-7
	Capstan Solenoid	670
	Capstan Solenoid Eye-Bolt	396-3
	Capstan Solenoid Stop	308
	Capstan Solenoid Felt Washer	FW-1/4-416-316
	Capstan Solenoid Pressure Spring	676
	Capstan Solenoid Return Spring	5757

Reference Numbers	Description	Ampex Catalog Number
<u>Head Assembly (Complete)</u>		
(Includes all cables and plugs)		
	With Half Track Heads	475-17
	With Full Track Heads	475-18
<u>Individually Replaceable Parts</u>		
	Gate Spring	438
	Gate Pins	DR-2-3-10
	Glass Rod Tape Guides	457
<u>CONTROL CIRCUIT ASSEMBLY (See Note 2)</u>		5703
C501	Drive Motor Start Condenser - supplied with Drive Motor - See Note 3.	
C502	80 MFD 150V Electrolytic Condenser	CO-105
C503	.05 MFD 400V Metallized Paper Condenser	CO-43
C504	.25 MFD 400V Metallized Paper Condenser	CO-45
C505	.05 MFD 400V Metallized Paper Condenser	CO-43
C506	.05 MFD 400V Metallized Paper Condenser	CO-43
C507	.01 MFD 400V Metallized Paper Condenser	CO-42
C508	.01 MFD 400V Metallized Paper Condenser	CO-42
C509	.05 MFD 400V Metallized Paper Condenser	CO-43
C510	.05 MFD 400V Metallized Paper Condenser	CO-43
C511	.05 MFD 400V Metallized Paper Condenser	CO-43
C512	3.75 MFD 330V Electrolytic Condenser	CO-86
C513	3.75 MFD 330V Electrolytic Condenser	CO-86
J501S	Female Chassis Connector - 21 Contact	PL-57S
J502S	Female Chassis Connector - 10 Contact	PL-207S
J503G	Female Chassis Connector - 8 Contact	PL-54S
J504S	Female Chassis Connector - 6 Contact	PL-55S
J505S	Female Chassis Connector - 8 Contact	PL-54S
J506S	Female Chassis Connector - 8 Contact	PL-54S

Note 2: The replacement Control Circuit Assembly includes all parts except those marked with an asterisk (\*).

Note 3: When ordering drive motor starting condensers, specify motor manufacturer, manufacturer's type number (found on the motor name plate), and the serial number of your machine.

Reference Number	Description	Amplex Catalog Number
* K501	Capstan Solenoid	B-670
K502	Play Relay - 3P2T	RL-21
K503	Fast Forward Relay - 3P2T	RL-21
K504	Rewind Relay - 3P2T	RL-21
* K505	Takeup Brake Solenoid	B-337
* K506	Rewind Brake Solenoid	B-337
P501P	Male Plug - 21 Contact - Latching	PL-309P
* P502P	Male Plug - 10 Contact - Latching - Remote Dummy	A-3461
* P503P	Male Plug - 8 Contact - Latching - 60 Cycle Dummy	A-567-1
P504P	Male Plug - 6 Contact - Latching	PL-101P
P505P	Male Plug - 3 Contact - Latching	PL-103P
P506P	Male Plug - 3 Contact - Latching	PL-103P
P507P	Male Plug - 4 Contact - Latching	PL-99P
R501	20 Ohm 5 Watt Fixed Wirewound Resistor	RE-309
R502	75 Ohm 50 Watt Fixed Wirewound Resistor	RE-129
R503	150 Ohm 50 Watt Adjustable Wirewound Resistor	RE-259
R504	750 Ohm 50 Watt Wirewound Resistor	RE-637
R505	150 Ohm 50 Watt Adjustable Wirewound Resistor	RE-259
R506	100 Ohm 1/2 Watt Composition Resistor	RE-444
R507	100 Ohm 1/2 Watt Composition Resistor	RE-444
R508	100 Ohm 1/2 Watt Composition Resistor	RE-444
R509	100 Ohm 1/2 Watt Composition Resistor	RE-444
R510	100 Ohm 1/2 Watt Composition Resistor	RE-444
SR501	Selenium Rectifier - Half Wave	SR-18
* S501	Safety Switch - SPST Micro-Switch	6582
* S502	Stop Pushbutton - SPST Normally Closed	SW-62
* S503	Tape Speed Switch - DPDT - Toggle	SW-5
* S504	Reel Size Switch - SPST - Toggle	SW-9
* S505	Play Pushbutton - SPST - Normally Open	SW-61
* S506	Fast Forward Pushbutton - SPST - Normally Open	SW-61
* S507	Rewind Pushbutton - SPST - Normally Open Pushbutton Guards	SW-61 361

### 6.3 ELECTRONIC ASSEMBLY - Catalog #5701 and 5701-1

C401	.25 MFD 400V Metallized Paper Condenser	CO-45
C402	25 MFD 25V Electrolytic Condenser	CO-59

Reference Number	Description	Ampex Catalog Number
C403	4 MFD 450V Electrolytic Condenser	CO-54
C404	25 MFD 25V Electrolytic Condenser	CO-59
C405	.25 MFD 400V Metallized Paper Condenser	CO-45
C406	.0005 MFD Padder Condenser	CO-325
C406	.0003 MFD Padder Condenser (3-3/4" - 7-1/2")	CO-122
C407	.0001 MFD Padder Condenser	CO-92
C407	.0005 MFD Padder Condenser (3-3/4" - 7-1/2")	CO-325
C408	.1 MFD 400V Metallized Paper Condenser	CO-101
C409	25 MFD 25V Electrolytic Condenser	CO-59
C410	10 MFD 450V Electrolytic Condenser	CO-55
C411	.05 MFD 400V Metallized Paper Condenser	CO-43
C412	1 MFD 400V Metallized Paper Condenser	CO-47
C413	16 MFD 150V Electrolytic Condenser	CO-56
C414	.1 MFD 400V Metallized Paper Condenser	CO-44
C415	.1 MFD 400V Metallized Paper Condenser	CO-44
C416	.1 MFD 200V Metallized Paper Condenser	CO-97
C417	.006 MFD 500V Mica Condenser + 5%	CO-13
C418	4 MFD 150V Electrolytic Condenser	CO-53
C419	50 MFD 25V Electrolytic Condenser	CO-60
C420	20 MFD 450V Electrolytic Condenser	CO-57
C421	.01 MFD 400V Metallized Paper Condenser	CO-42
C422	4 MFD 150V Electrolytic Condenser	CO-53
C423	25 MFD 25V Electrolytic Condenser	CO-59
C424	.1 MFD 400V Metallized Paper Condenser	CO-44
C425	.005 MFD 500V Mica Condenser + 5%	CO-12
C425	.015 MFD 200V Mica Condenser $\pm$ 5% (3-3/4" - 7-1/2")	CO-230
C426	.0025 MFD 500V Mica Condenser $\pm$ 5%	CO-3
C426	.005 MFD 500V mica Condenser $\pm$ 5% (3-3/4" - 7-1/2")	CO-12
C427	25 MFD 25V Electrolytic Condenser	CO-59
C428	4 MFD 450V Electrolytic Condenser	CO-54
C429	.25 MFD 400V Metallized Paper Condenser	CO-47
C430	2000 MFD 15V Electrolytic Condenser	CO-66
C431	20 MFD 450V Electrolytic Condenser	CO-57
C432	.0004 MFD 500V Mica Condenser (Matched) $\pm$ 5%	CO-89
C433	.004 MFD 500V Mica Condenser + 5%	CO-11
C434	.004 MFD 500V Mica Condenser $\pm$ 5%	CO-11
C435	.0004 MFD 500V Mica Condenser (Matched) $\pm$ 5%	CO-89
C436	.1 MFD 400V Metallized Paper Condenser	CO-44
C437	.0005 MFD 500V Silver Mica Condenser $\pm$ 5%	CO-5



Reference Number	Description	Ampex Catalog Number
C438	.001 MFD Padder Condenser	CO-91
C439	.0005 MFD Mica Condenser $\pm$ 10%	CO-19
C440	.25 MFD 400V Metallized Paper Condenser	CO-45
F401	1 Amp Fuse, 5 $\phi$ -Blo	FU-7
F402	3 Amp Fuse	FU-8
I401	Record Indicator (Neon)	DL-4
J401S	Cannon XL-3-13 Chassis Connector	PS-58-3
J402P	AN-3102-10S-3P Box Mount Connector	PS-59F
J403S	Phone Jack - Open Circuit	JA-8
J404P	Cannon XL-3-14 Chassis Connector	PL-4P
J405P	AN-3102-10S-4P Box Mount Connector	PL-31P
J406P	AN-3102-10S-2P Box Mount Connector	PL-62P
J407S	Jones S-304-AB Chassis Connector	PL-56S
J408S	Jones S-308-AB Chassis Connector	PL-54S
J409P	Hubbell #7466 Chassis Connector	PL-104P
J410S	Plug, 115 V. Outlet	PL-141S
J411S	Phone Jack - Open Circuit	JA-8
K401	Record Relay, 3P2T, 115 V. DC	B-5760
L401	20 MF R. F. Choke	CH-8
M401	4" VU Meter	ME-2

NOTE: ALL RESISTORS  $\pm$  10% UNLESS OTHERWISE SPECIFIED

R401	150,000 Ohm 1/2 Watt Composition Resistor	RE-296
R402	100 Ohm 1/2 Watt Composition Resistor	RE-602
R403	100 Ohm 1/2 Watt Composition Resistor	RE-602
R404	150,000 Ohm 1/2 Watt Composition Resistor	RE-296
R405	1 Meg. 1/2 Watt Composition	RE-290
R406	1,200 Ohm 1/2 Watt Composition Resistor	RE-335
R407	330,000 Ohm 1/2 Watt Composition Resistor	RE-427
R408	100,000 Ohm 1/2 Watt Film Resistor $\pm$ 1%	RE-571
R409	100,000 Ohm Audio Taper Potentiometer	RE-584
R410	2,200 Ohm 1/2 Watt Composition Resistor	RE-369
R411	47,000 Ohm 1 Watt Composition Resistor	RE-22

Reference Number	Description	Ampex Catalog Number
R412	100,000 Ohm 1/2 Watt Composition Resistor	RE-300
R413	330,000 Ohm 1/2 Watt Composition Resistor $\pm 5\%$	RE-607
R414	100,000 Ohm 1/2 Watt Composition Resistor	RE-300
R415	33,000 Ohm 1/2 Watt Film Resistor $\pm 1\%$	RE-608
R416	2,200 Ohm 1/2 Watt Composition Resistor	RE-369
R417	47,000 Ohm 1 Watt Composition Resistor	RE-22
R418	470,000 Ohm 1/2 Watt Composition Resistor	RE-302
R419	2,200 Ohm 1/2 Watt Composition Resistor	RE-369
R420	470 Ohm 1/2 Watt Composition Resistor	RE-333
R421	22,000 Ohm 2 Watt Composition Resistor	RE-171
R422	47,000 Ohm 1/2 Watt Composition Resistor	RE-299
R423	1 Meg. 1/2 Watt Composition Resistor	RE-290
R424	50,000 Ohm Linear Taper Potentiometer	RE-226
R425	470,000 Ohm 1/2 Watt Composition Resistor	RE-302
R426	15,000 Ohm 10 Watt Wirewound Resistor	RE-92
R427	100,000 Ohm 2 Watt Composition Resistor	RE-179
R428	10,000 Ohm Audio Taper Potentiometer	RE-315
R429	330,000 Ohm 1/2 Watt Film Resistor $\pm 1\%$	RE-599
R430	2,200 Ohm 1/2 Watt Film Resistor $\pm 1\%$	RE-611
R431	470 Ohm 1/2 Watt Composition Resistor	RE-333
R432	470 Ohm 1/2 Watt Composition Resistor	RE-333
R433	330,000 Ohm 1/2 Watt Film Resistor	RE-599
R434	2,200 Ohm 1/2 Watt Composition Resistor	RE-369
R435	100,000 Ohm Audio Taper Potentiometer	RE-227
R436	1 Meg. 1/2 Watt Film Resistor $\pm 1\%$	RE-600
R437	47,000 Ohm 1/2 Watt Composition Resistor	RE-299
R438	1 Meg. Audio Taper Potentiometer	RE-585
R439	1 Meg. 1/2 Watt Composition Resistor	RE-290
R440	330,000 Ohm 1/2 Watt Composition Resistor	RE-427
R441	2,700 Ohm 1/2 Watt Composition Resistor	RE-373
R442	220 Ohm 1/2 Watt Composition Resistor	RE-330
R443	150,000 Ohm 1/2 Watt Composition Resistor	RE-296
R444	560,000 Ohm 2 Watt Composition Resistor	RE-605
R445	1,500 Ohm 1/2 Watt Composition Resistor	RE-332
R446	10,000 Ohm 2 Watt Composition Resistor	RE-168
R447	47,000 Ohm 1 Watt Composition Resistor	RE-22
R448	22,000 Ohm 1/2 Watt Composition Resistor	RE-298
R449	2,700 Ohm 1/2 Watt Composition Resistor	RE-373
R450	560 Ohm 1/2 Watt Composition Resistor	RE-446

Reference Number	Description	Ampex Catalog Number
R451	100 Ohm 1 Watt Composition Resistor	RE-260
R452	3,600 Ohm 1/2 Watt Film Resistor + 1%	RE-597
R453	2,000 Ohm 10 Watt Wirewound Resistor	RE-82
R454	100 Ohm 1 Watt Composition Resistor	RE-260
R455	47,000 Ohm 1/2 Watt Composition Resistor	RE-299
R456	47,000 Ohm 1/2 Watt Composition Resistor	RE-299
R457	100 Ohm 1 Watt Composition Resistor	RE-260
R458	7 Ohm 1 Watt Film Resistor + 1%	RE-462
R459	500 Ohm 10 Watt Adjustable Wirewound Resistor	RE-277
R460	40,000 Ohm Wirewound Potentiometer	RE-278
R461	150,000 Ohm 1/2 Watt Composition Resistor	RE-296
R462	33,000 Ohm 1/2 Watt Film Resistor + 1% (3-3/4"-7-1/2")	RE-608
S401	Input Transfer Switch - 3P3T Rotary	SW-7
S402	Equalization Switch - 3P2T Rotary	SW-8
S403	Record Switch - Pushbutton SPST - Normally Open	SW-34
S404	Line Termination Switch - SPST Toggle	SW-9
S405	Meter and Output Switch - 3P4T Rotary	SW-13
S406	AC Power Switch - SPST Toggle	SW-9
T401	Microphone Input Transformer	1153
T402	Output Transformer	1154
T403	Erase Transformer	1011
V401	12SJ7 Vacuum Tube	TU-11
V402	12SJ7 Vacuum Tube	TU-11
V403	12SJ7 Vacuum Tube	TU-11
V404	6C5 or 6J5 Vacuum Tube	TU-3
V405	12SJ7 Vacuum Tube (Selected)	TU-12
V406	12SJ7 Vacuum Tube	TU-11
V407	6F6 Vacuum Tube	TU-8
V408	6C5 or 6J5 Vacuum Tube	TU-3
V409	6SN7-GT Vacuum Tube	TU-13
	AC Power Cable	2413
	Turret Tube Sockets	1208
	Fuse Extractor Post	FE-1
	Equalization, Meter & Output Switch Knobs	KN-3
	Record and Playback Level Knobs	KN-4
	Input Transfer Switch Knob	KN-8

Reference Number	Description	Ampex Catalog Number
6.4 <u>POWER SUPPLY</u> - Catalog #3741 (Console) Catalog #3741-1 (Portable & Rack)		
C601	20 MFD 450V Electrolytic Condenser	CO-57
C602	20 MFD 450V Electrolytic Condenser	CO-57
C603	30-30-20 MFD 475V Electrolytic Condenser	CO-244
C604	20 MFD 450V Electrolytic Condenser	CO-57
J601P	Jones P-303-CCT-L Cable Connector	PL-103P
L601	8H 80 MA Filter Choke	1155
L602	8H 80 MA Filter Choke	1155
CR 601	Selenium Rectifier - Full Wave	SR-3
T601	Power Transformer	3953
V601	5Y3G Vacuum Tube	TU-14
	Power Supply Cable	2435
6.5 <u>MISCELLANEOUS</u>		
A701	Remote Record Lamp - 120 V, 6 Watt Lamp Base - Red	LA-6 DL-7
A702	Remote Tape Motion Lamp - 120 V, 6 Watt Lamp Base - Green	LA-6 DL-8
J701P	Remote Chassis Connector - 10 Contact, Male Remote Control Cable (with plugs)	PL-139P 5795
S701	Fast Forward Pushbutton - SPST Normally Open	SW-61
S702	Rewind Pushbutton - SPST Normally Open	SW-61
S703	Stop Pushbutton - SPST Normally Closed	SW-62
S704	Start Pushbutton - SPST Normally Open	SW-61
S705	Record Pushbutton - SPST Normally Open	SW-61

Reference Number	Description	Ampex Catalog Number
	Mechanical Assembly Case for Two-Case Portable	5727
	Electronic Assembly Case for Two-Case Portable with extra space	3693
	Console Cabinet	5728
	Power Interconnecting Extension Cable	1758-1
	Power Supply Extension Cable	3814
	Remote Control Box	5763
	Four Channel Mixer-Pre-Amplifier	3761
	Editing Knob (Portable & Console)	1917
	Reel Hold Down Knob (Rack)	9093
	10-1/2" NARTB Reel	539
	Ampex Alignment Tape (for 7-1/2" - 15" Machines)	4494
	Ampex Alignment Tape (for 3-3/4" - 7-1/2" Machines)	5563
	Ampex Head Demagnetizer	704
	Bias Interconnecting Cable, 16-inch	3730-2

NOTE: ORDER PARTS BY AMPEX CATALOG NUMBER ONLY!



MODEL 350 CONSOLE  
AMPEX ELECTRIC CORPORATION  
REDWOOD CITY, CALIFORNIA

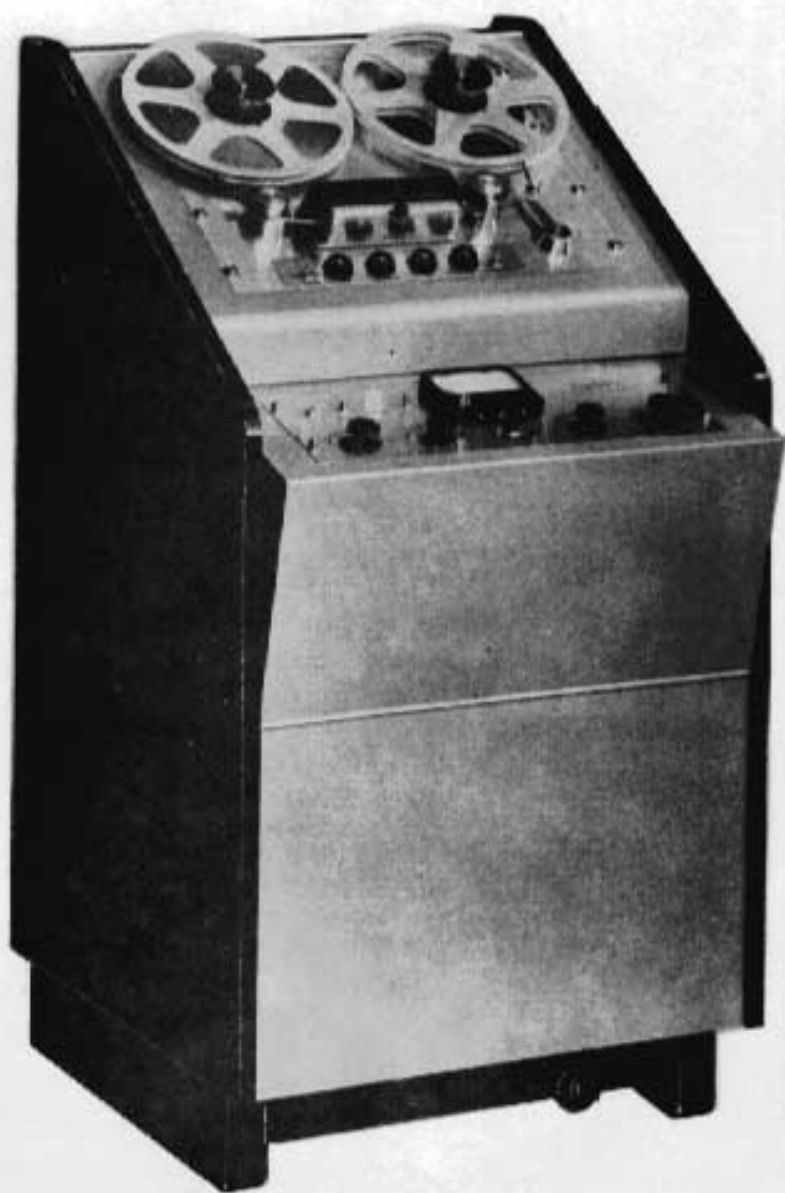

MODEL 350 CONSOLE  
AMPEX ELECTRIC CORPORATION  
REDWOOD CITY, CALIFORNIA



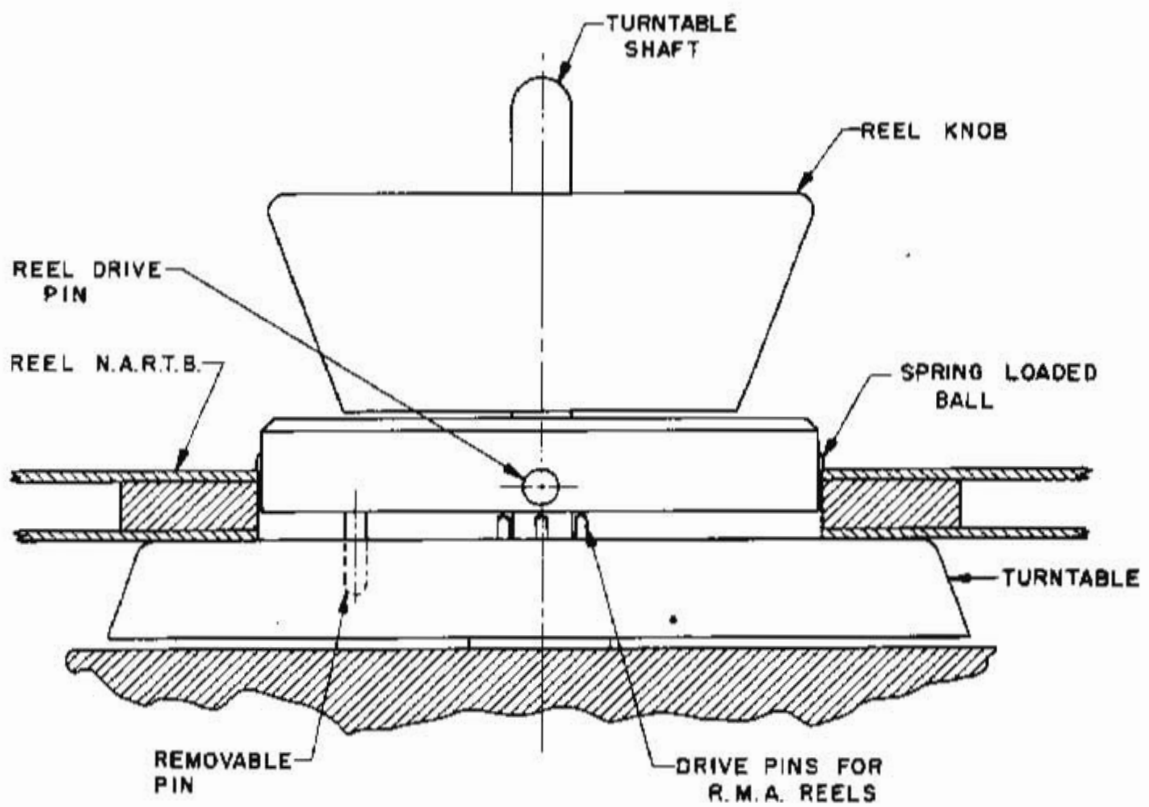

CAUTION:- DO NOT PUSH KNOB ALL THE WAY DOWN TO THE TURNTABLE OR SPRING LOADED BALLS WILL NOT HOLD REEL IN PLACE.

**REEL HOLD-DOWN KNOB**  
 AMPEX ELECTRIC CORPORATION  
 REDWOOD CITY, CALIFORNIA.

FIG. O

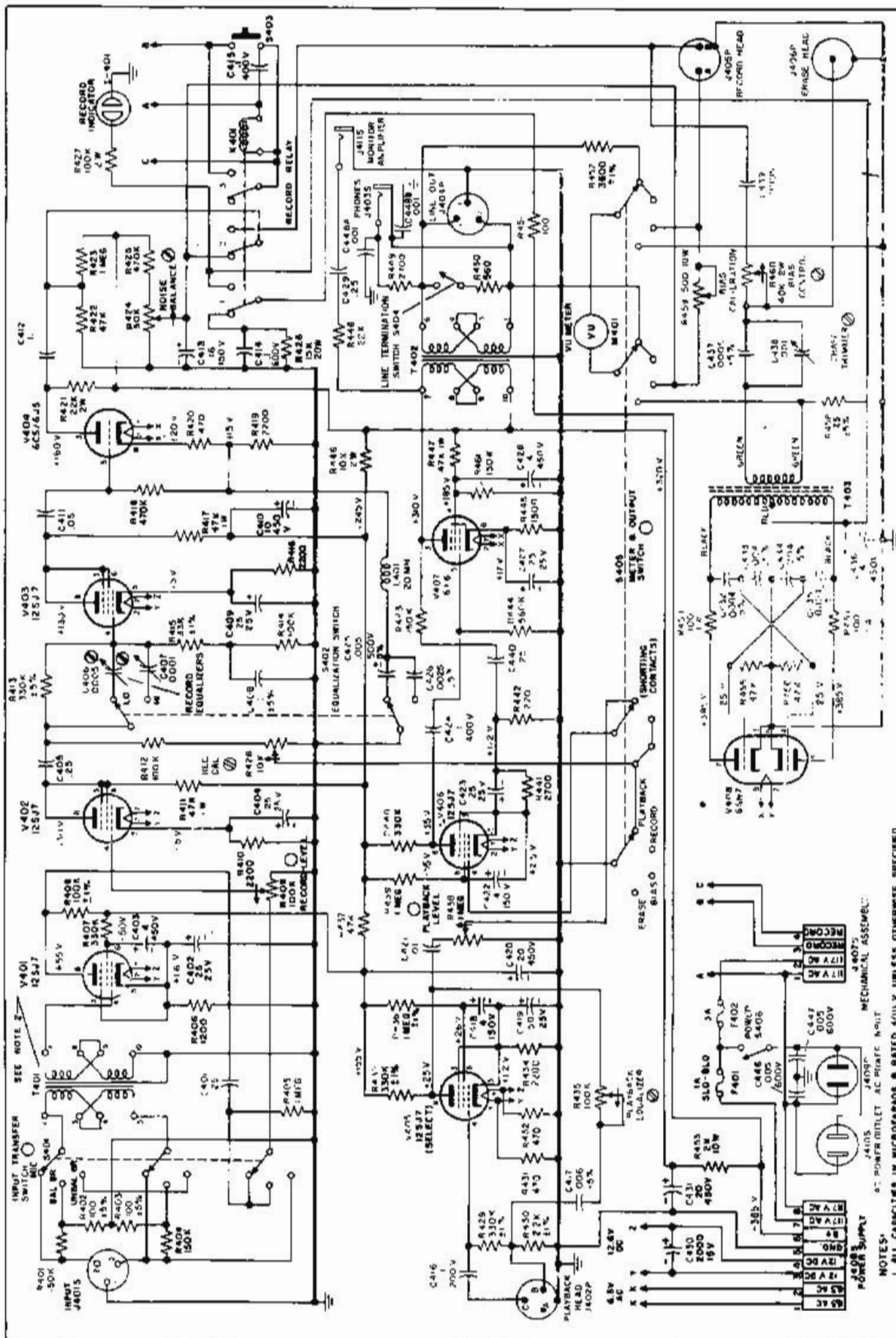

ELECTRONIC ASSEMBLY  
 CATALOG NO. 570IR3  
 AMPEX ELECTRIC CORPORATION  
 REDWOOD CITY, CALIFORNIA

- NOTES:
1. ALL CAPACITIES IN MICROFARADS, & RATED 400V UNLESS OTHERWISE SPECIFIED.
  2. FOR 50 & 50 OHMS MICROPHONE, SEE INSTALLATION.
  3. ALL VOLTAGES MEASURED WITH 20,000 OHMS PER VOLT METER WITH 117VAC LINE VOLTAGE. ALL READINGS EXCEPT V408 OSCILLATOR VOLTAGES TAKEN WITH W401 DE-ENERGIZED.
  4. ALL RESISTORS IN OHMS 1%, & RATED 1/2 WATT UNLESS OTHERWISE SPECIFIED.

FIG. 1

© 1962 AMPEX. PANEL CONTROL. Ⓞ SCREWDRIVER ADJUSTMENT.

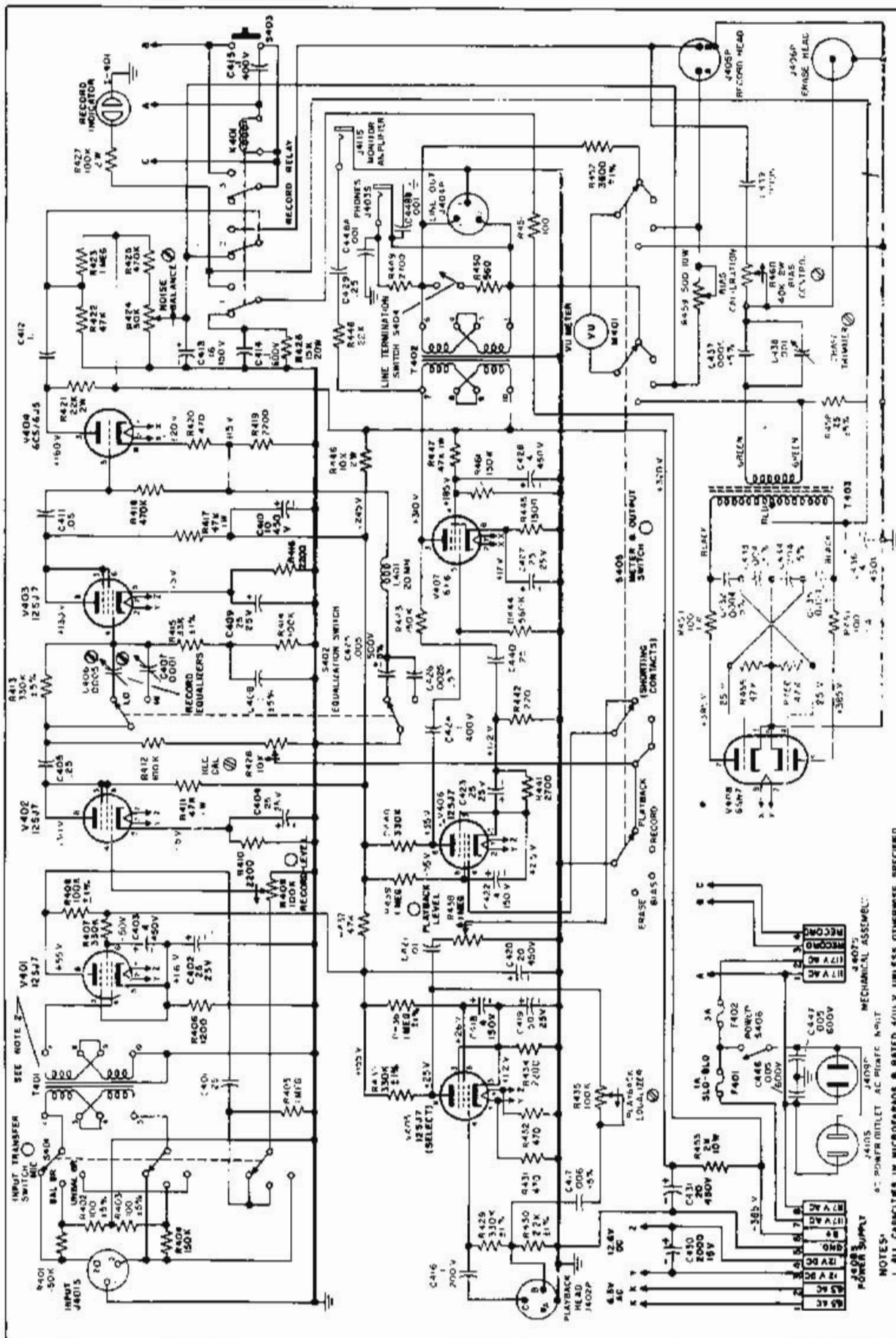

ELECTRONIC ASSEMBLY  
 CATALOG NO. 570IR3  
 AMPEX ELECTRIC CORPORATION  
 REDWOOD CITY, CALIFORNIA

- NOTES:
1. ALL CAPACITIES IN MICROFARADS, & RATED 400V UNLESS OTHERWISE SPECIFIED.
  2. FOR 30 & 50 OHMS MICROPHONE, SEE INSTALLATION.
  3. ALL VOLTAGES MEASURED WITH 20,000 OHMS PER VOLT METER WITH 117VAC LINE VOLTAGE. ALL READINGS EXCEPT V408 OSCILLATOR VOLTAGES TAKEN WITH W401 DE-ENERGIZED.
  4. ALL RESISTORS IN OHMS 10%, & RATED 1/2 WATT UNLESS OTHERWISE SPECIFIED.

FIG. 1

⊙ TRADE: PANEL CONTROL. ⊕ SCREWDRIVER ADJUSTMENT.

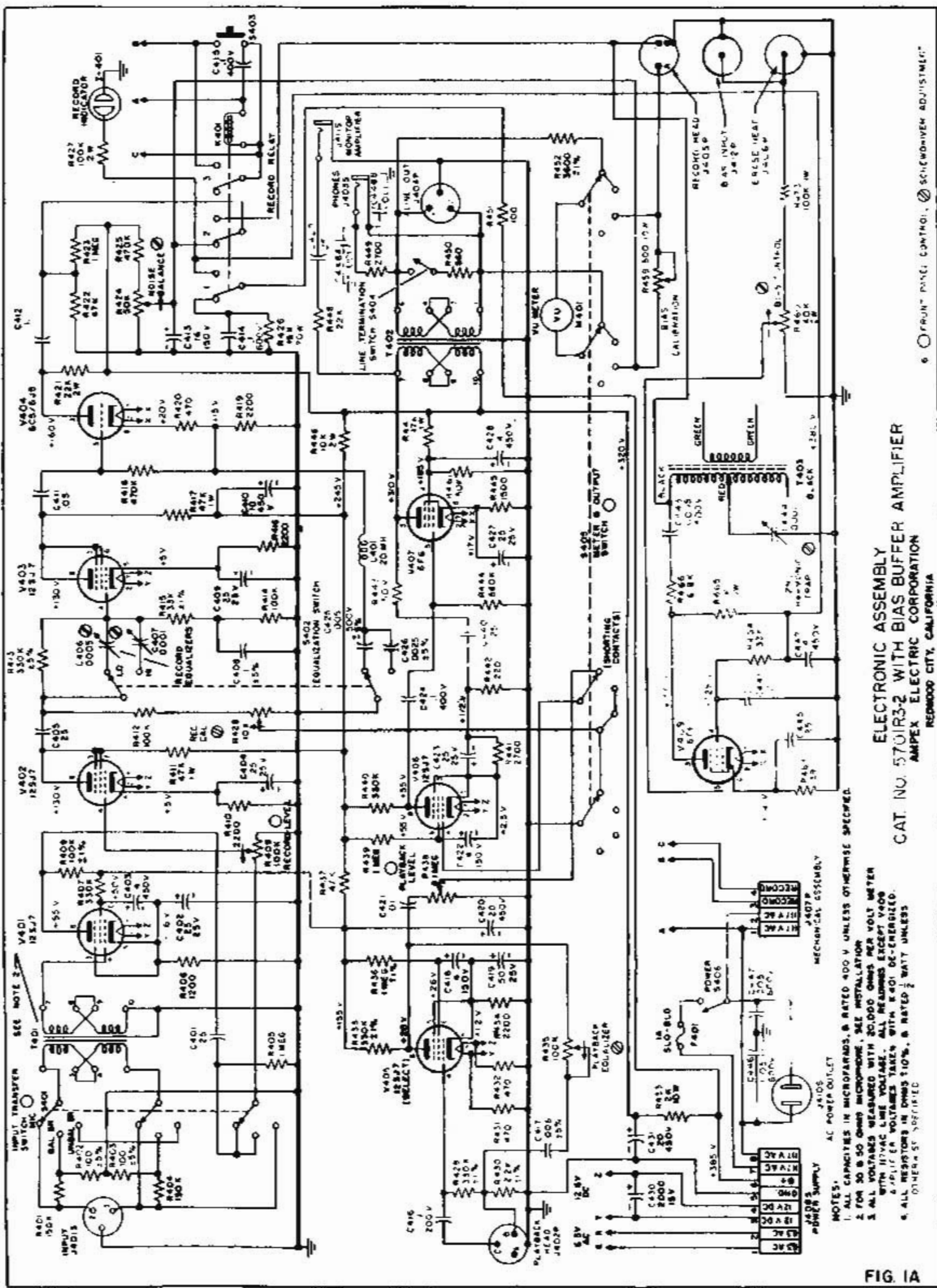

**ELECTRONIC ASSEMBLY WITH BIAS BUFFER AMPLIFIER**  
**CAT. NO. 570IR3-2 WITH BIAS BUFFER AMPLIFIER**  
**AMPEX ELECTRIC CORPORATION**  
**REDWOOD CITY, CALIFORNIA**

- NOTES:
1. ALL CAPACITORS IN MICROFARADS, & RATED 400 V UNLESS OTHERWISE SPECIFIED.
  2. FOR 50 & 50 OHM MICROFORMS, SEE INSTALLATION.
  3. ALL VOLTMETERS MEASURED WITH 20,000 OHMS PER VOLT METER WITH 110VAC LINE VOLTAGE. ALL READINGS EXCEPT V408 & V409 VOLTAGES TAKEN WITH 400 Ω DE-CERIALIZED.
  4. ALL RESISTORS IN OHMS 10%, & RATED 1/2 WATT UNLESS OTHERWISE SPECIFIED.

**FIG. 1A**

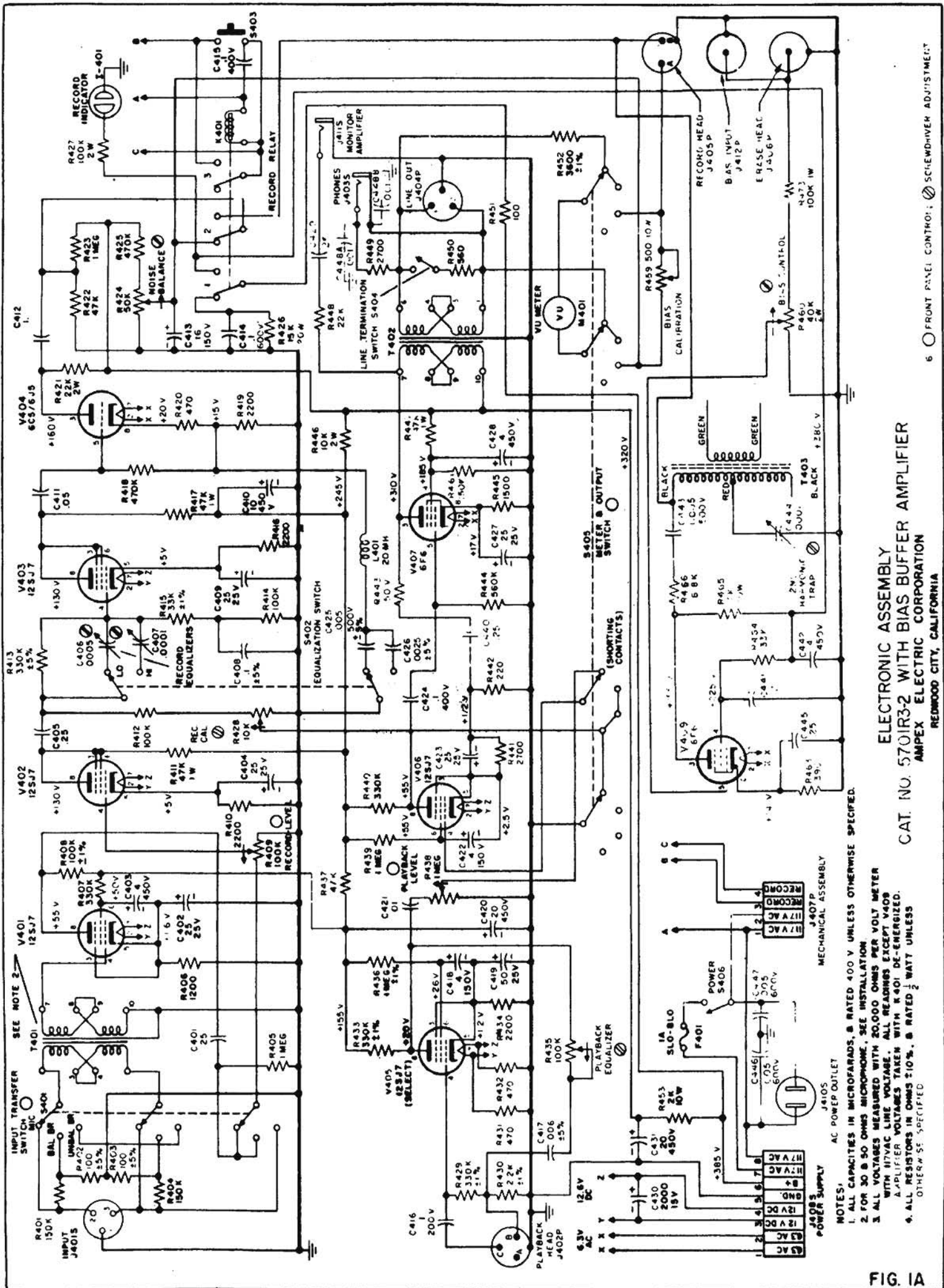

**ELECTRONIC ASSEMBLY  
CAT. NO. 5701R3-2 WITH BIAS BUFFER AMPLIFIER**  
AMPEX ELECTRIC CORPORATION  
REDWOOD CITY, CALIFORNIA

- NOTES:**
1. ALL CAPACITIES IN MICROFARADS, B RATED 400 V UNLESS OTHERWISE SPECIFIED.
  2. FOR 30 B 50 OHMS MICROPHONE, SEE INSTALLATION.
  3. ALL VOLTAGES MEASURED WITH 20,000 OHMS PER VOLT METER WITH HTVAC LINE VOLTAGE. ALL READINGS EXCEPT V409 AMPLIFIER VOLTAGES TAKEN WITH K401 DE-ENERGIZED.
  4. ALL RESISTORS IN OHMS  $\pm 10\%$ , B RATED  $\frac{1}{2}$  WATT UNLESS OTHERWISE SPECIFIED.

**FIG. 1A**



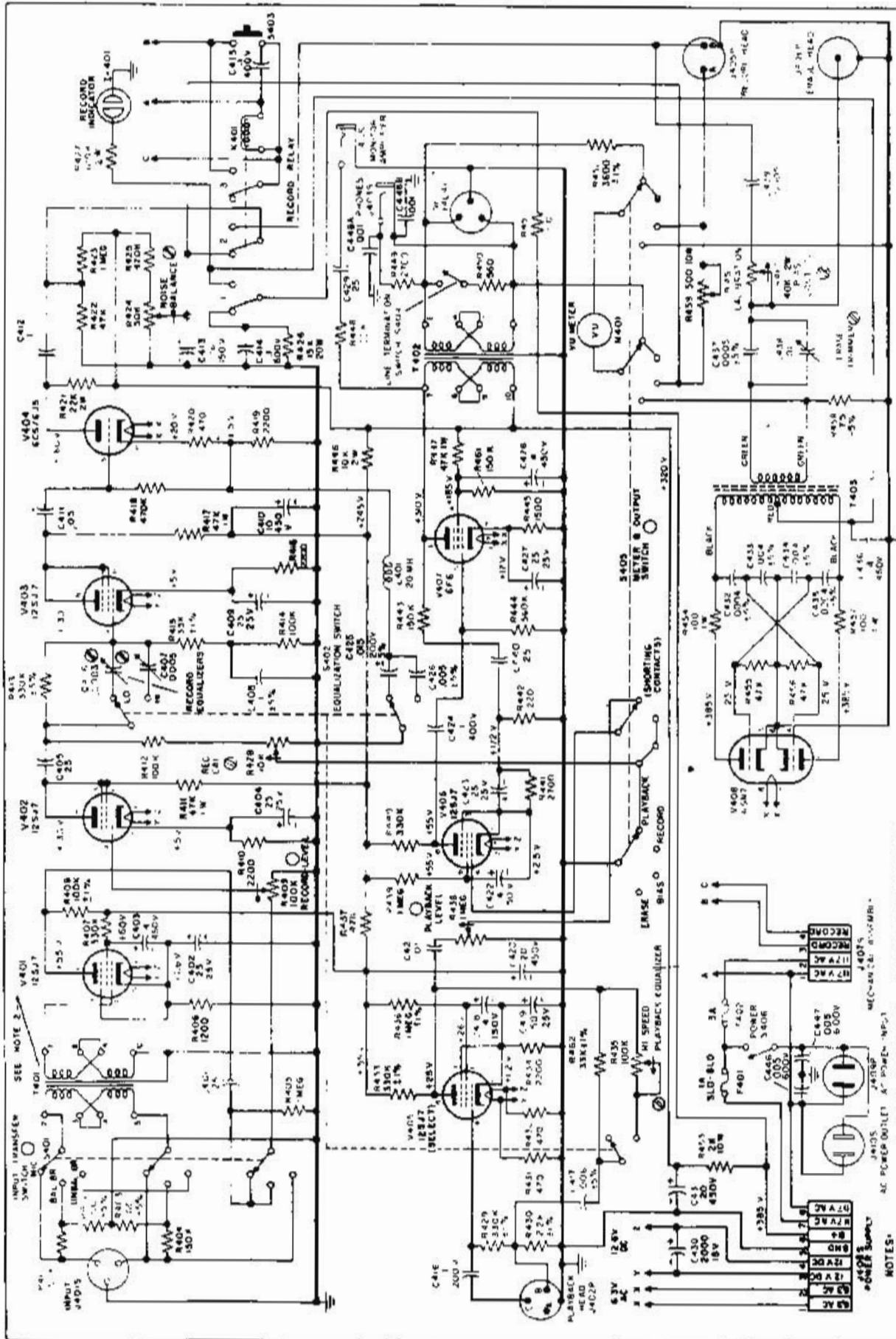

**ELECTRONIC ASSEMBLY**  
**(3 3/4 & 7 1/2" SPEED)**  
**CATALOG NO 570IR3-1**  
**AMPEX ELECTRIC CORPORATION**  
**REDWOOD CITY, CALIFORNIA**

- NOTES:**
1. ALL CAPACITORS IN MICROFARADS, & RATED 40% V UNLESS OTHERWISE SPECIFIED.
  2. FOR 30 & 50 OHMS MICROPHONES, SEE INSTALLATION.
  3. ALL VOLTAGES MEASURED WITH 20,000 OHMS PER VOLT METER WITH 117VAC LINE VOLTAGE. ALL READINGS EXCEPT V-408 OSCILLATOR VOLTAGES TAKEN WITH 400 OHM DE-ENERGIZED.
  4. ALL RESISTORS IN OHMS 1%, & RATED 1/2 WATT UNLESS OTHERWISE SPECIFIED.

**FIG. 2**

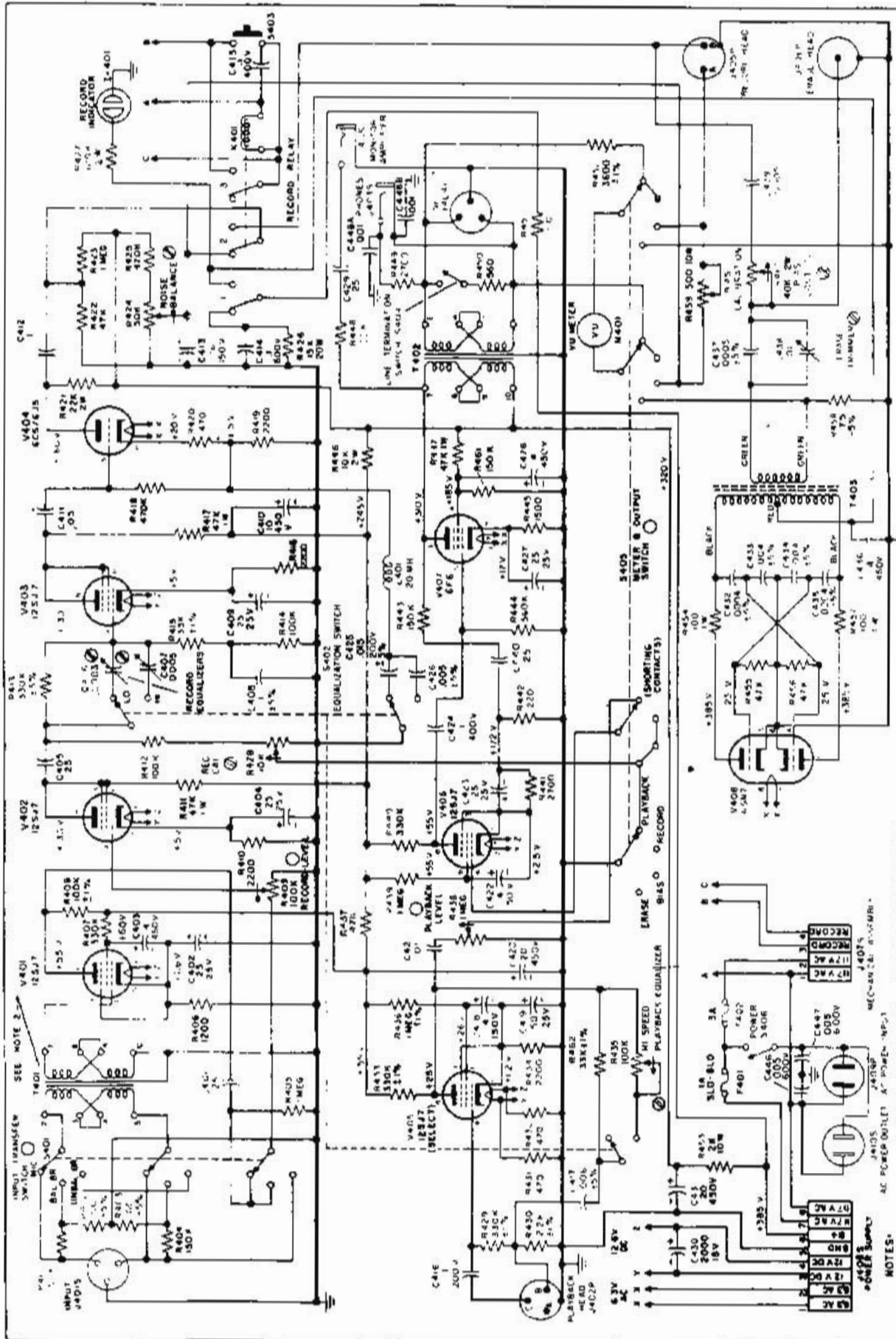

**ELECTRONIC ASSEMBLY**  
**(3 3/4 & 7 1/2" SPEED)**  
**CATALOG NO 570IR3-1**  
**AMPEX ELECTRIC CORPORATION**  
**REDWOOD CITY, CALIFORNIA**

- NOTES:**
1. ALL CAPACITORS IN MICROFARADS, & RATED 40% V UNLESS OTHERWISE SPECIFIED.
  2. FOR 30 & 50 OHMS MICROPHONES, SEE INSTALLATION.
  3. ALL VOLTAGES MEASURED WITH 20,000 OHMS PER VOLT METER WITH 117VAC LINE VOLTAGE. ALL READINGS EXCEPT V-408 OSCILLATOR VOLTAGES TAKEN WITH 400-Ω DE-ENERGIZED.
  4. ALL RESISTORS IN OHMS 1%, & RATED 1/2 WATT UNLESS OTHERWISE SPECIFIED.

**FIG. 2**



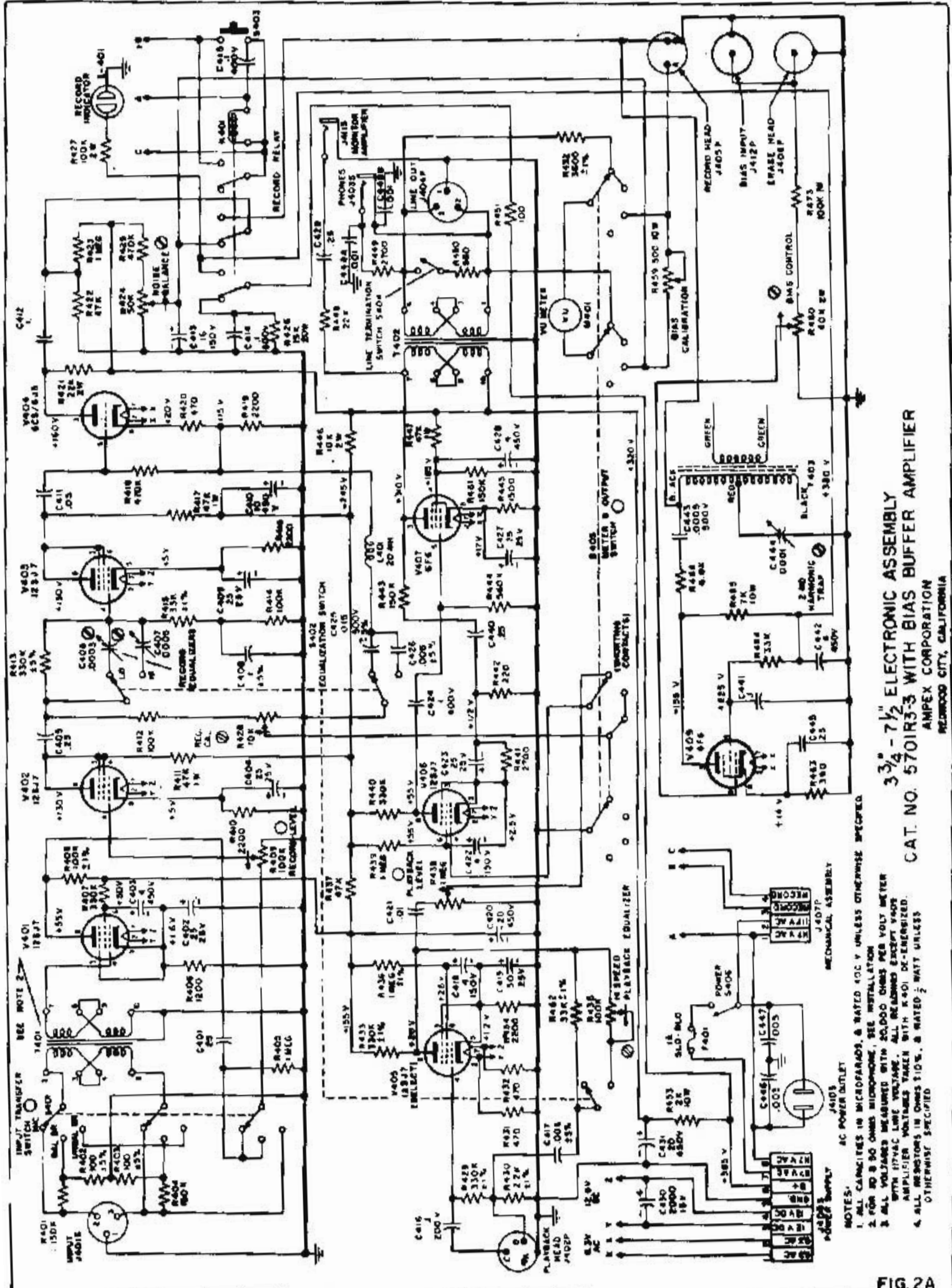

3 3/4 - 7 1/2" ELECTRONIC ASSEMBLY WITH BIAS BUFFER AMPLIFIER  
 CAT. NO. 5701R3-3  
 AMPLEX CORPORATION  
 REDWOOD CITY, CALIFORNIA

- NOTES:
1. ALL CAPACITORS IN MICROFARADS, & RATED 100 V UNLESS OTHERWISE SPECIFIED.
  2. FOR 50 & 50 OHM MICROPHONE, SEE INSTALLATION.
  3. ALL VOLTAGES MEASURED WITH 50,000 OHMS PER VOLT METER WITH 117VAC LINE VOLTAGE. ALL READINGS EXCEPT V405 AMPLIFIER VOLTAGES TAKEN WITH K-401 DE-ENERGIZED.
  4. ALL RESISTORS IN OHMS 5.0%, & RATED 1/2 WATT UNLESS OTHERWISE SPECIFIED.

FIG. 2A

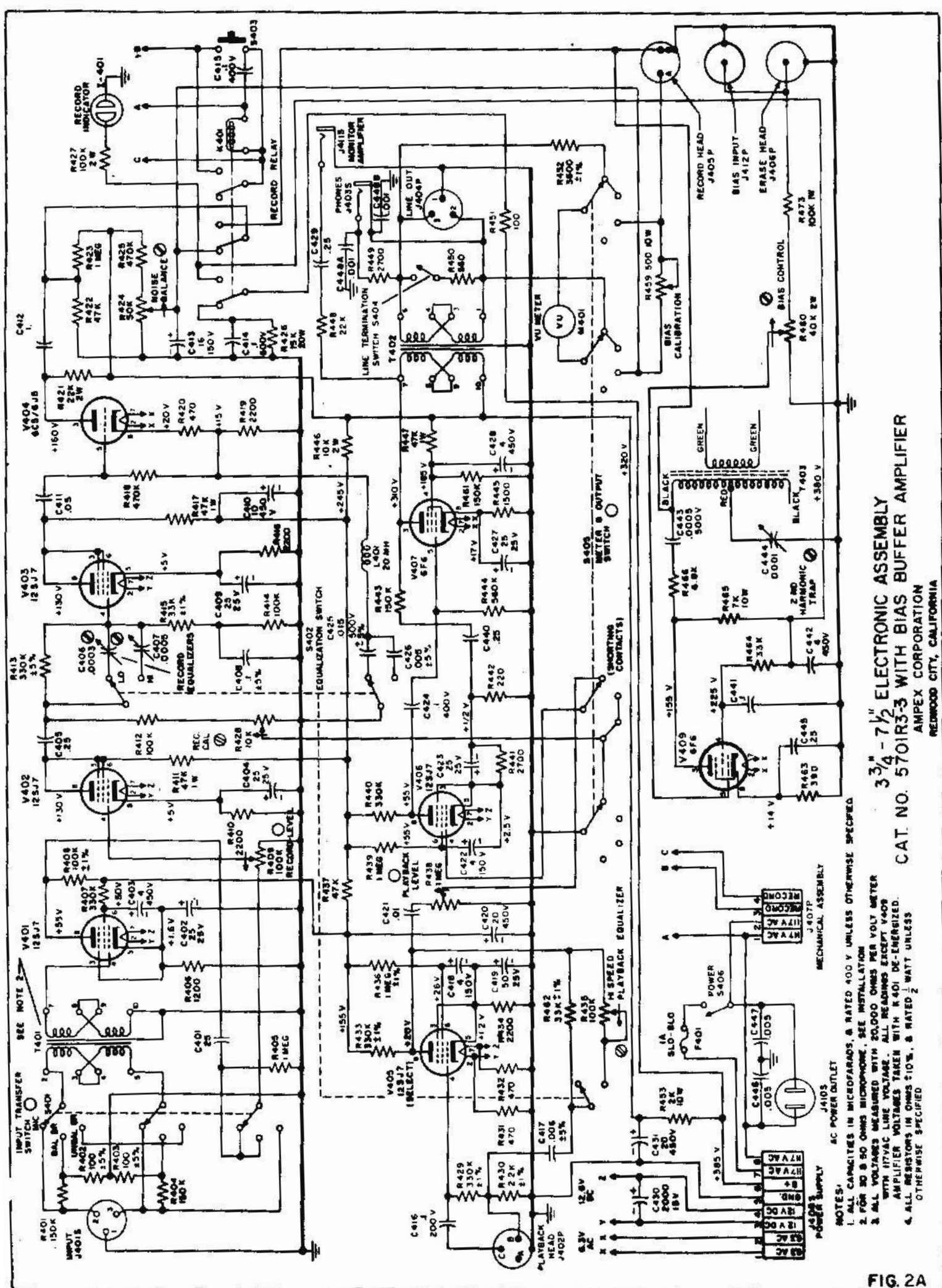

**3 3/4" - 7 1/2" ELECTRONIC ASSEMBLY  
CAT. NO. 5701R3-3 WITH BIAS BUFFER AMPLIFIER**

AMPEX CORPORATION  
REDWOOD CITY, CALIFORNIA

- NOTES:
1. ALL CAPACITIES IN MICROFARADS, & RATED 100 V UNLESS OTHERWISE SPECIFIED
  2. FOR 50 & 50 OHMS MICROPHONE, SEE INSTALLATION
  3. ALL VOLTAGES MEASURED WITH 20,000 OHMS PER VOLT METER WITH 177VAC LINE VOLTAGE. ALL READINGS EXCEPT V409 AMPLIFIER VOLTAGES TAKEN WITH K401 DE-ENERGIZED.
  4. ALL RESISTORS IN OHMS ±10%, & RATED 1/2 WATT UNLESS OTHERWISE SPECIFIED

FIG. 2A

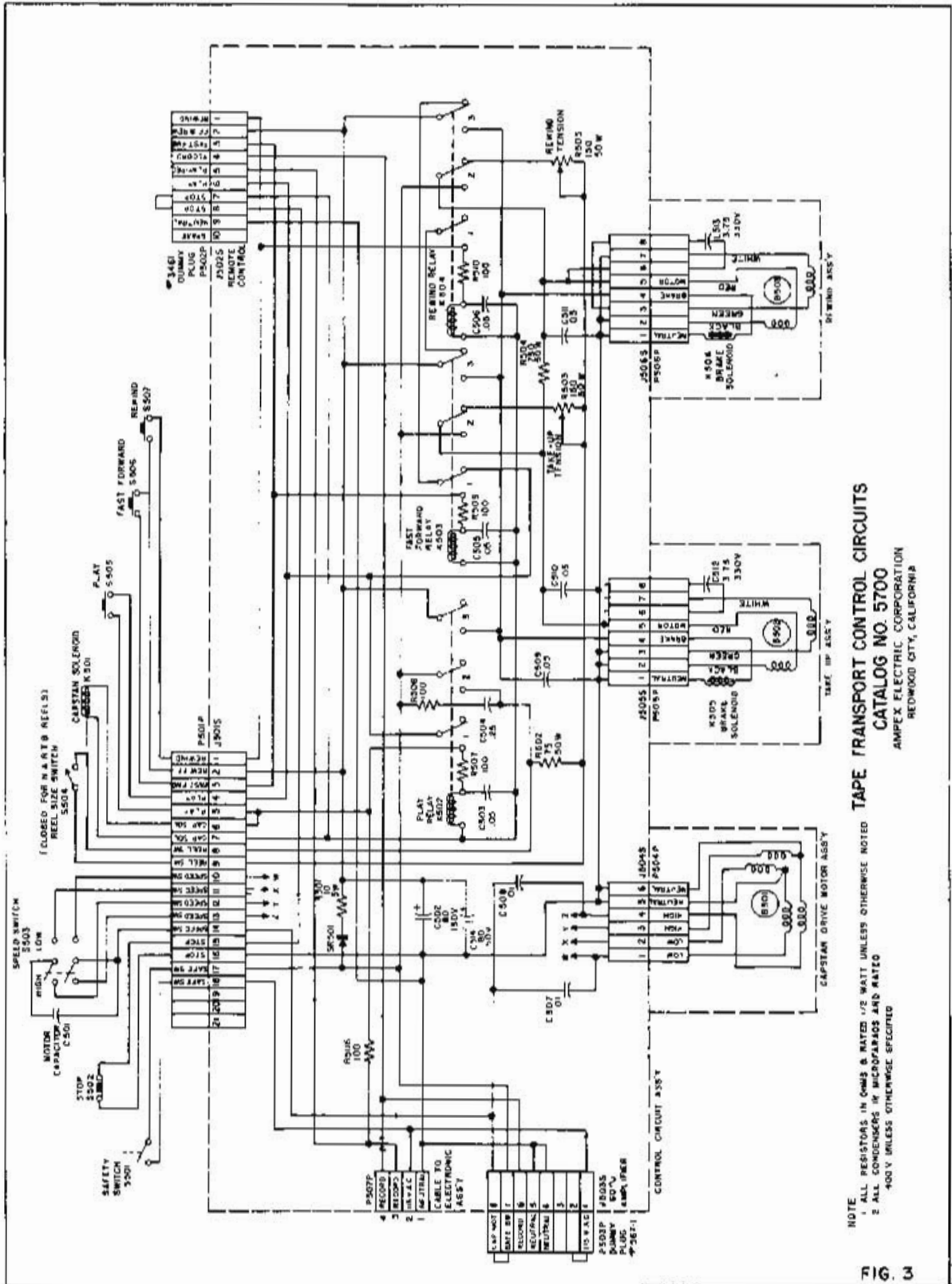

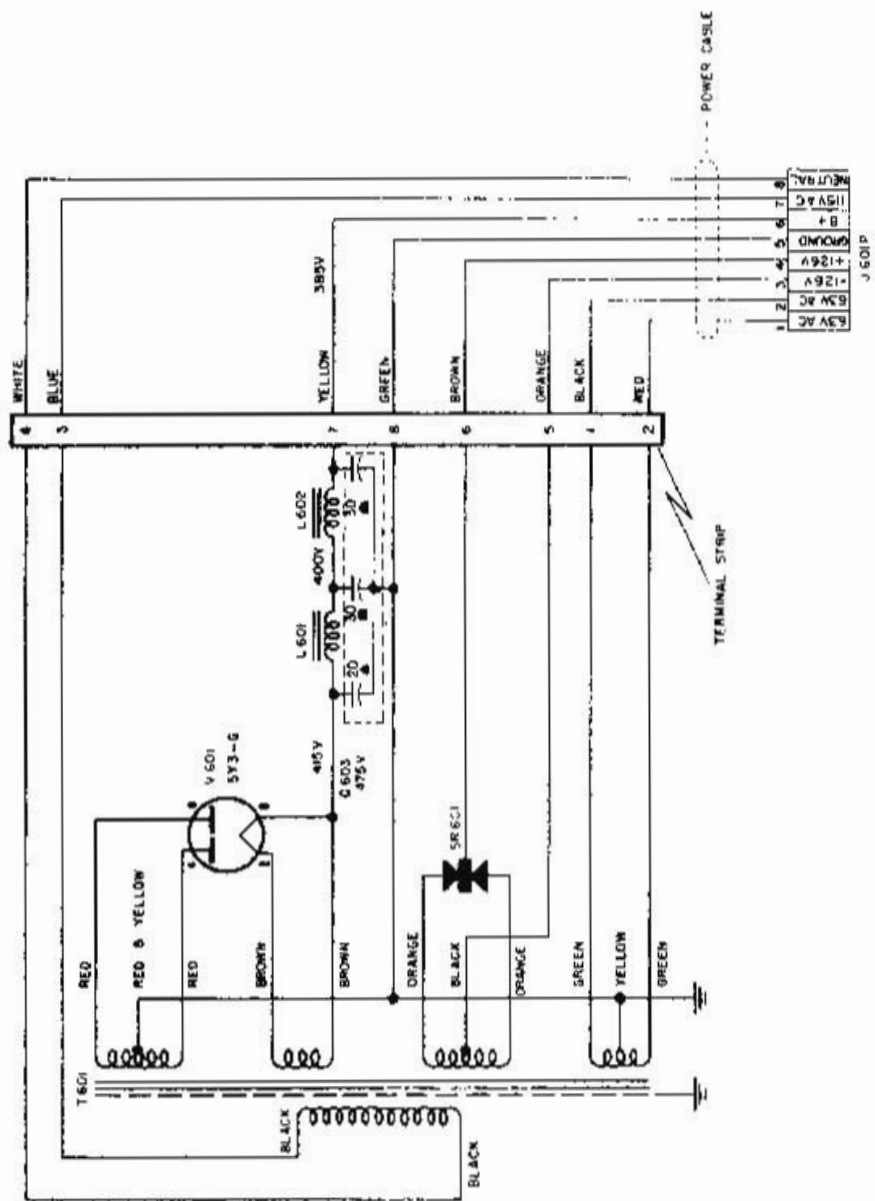

NOTE: ALL VOLTAGES MEASURED WITH  
 20,000 OHMS PER VOLT METER WITH  
 117V AC POWER INPUT. J-601P IS  
 CONNECTED TO THE ELECTRONICS WITH  
 THE RECORD RELAY DE-ENERGIZED

**POWER SUPPLY**  
**CAT. NO. 3741**  
 AMPEX ELECTRIC CORPORATION  
 REDWOOD CITY, CALIFORNIA

FIG. 4

**FIG. 5A**  
**INPUT FOR HIGH IMPEDANCE MICROPHONE**  
 (SEE INSTALLATION)

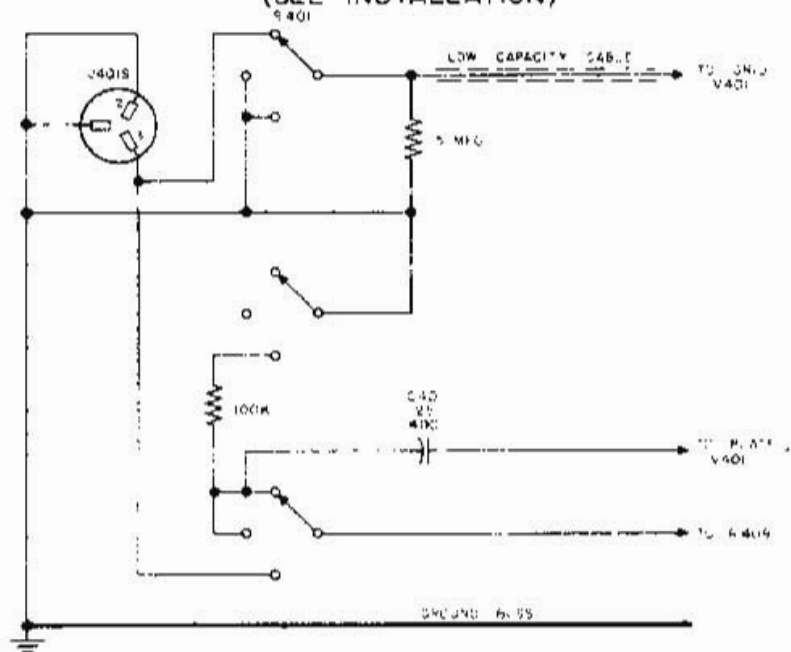

**FIG. 5B**  
**INPUT TRANSFORMER CONNECTION FOR**  
**30 & 50 OHMS MICROPHONES**  
 (SEE INSTALLATION)

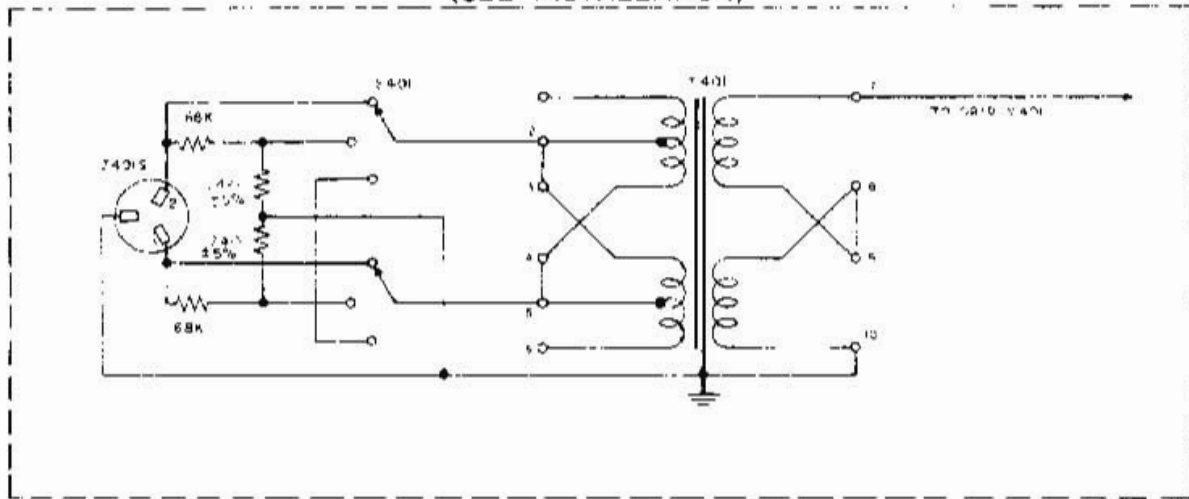

**MODEL 350**

PLAYBACK AMPLIFIER RESPONSE  
 AMPEX AUDIO RECORDERS  
 AMPEX ELECTRIC CORPORATION  
 REDWOOD CITY, CALIFORNIA

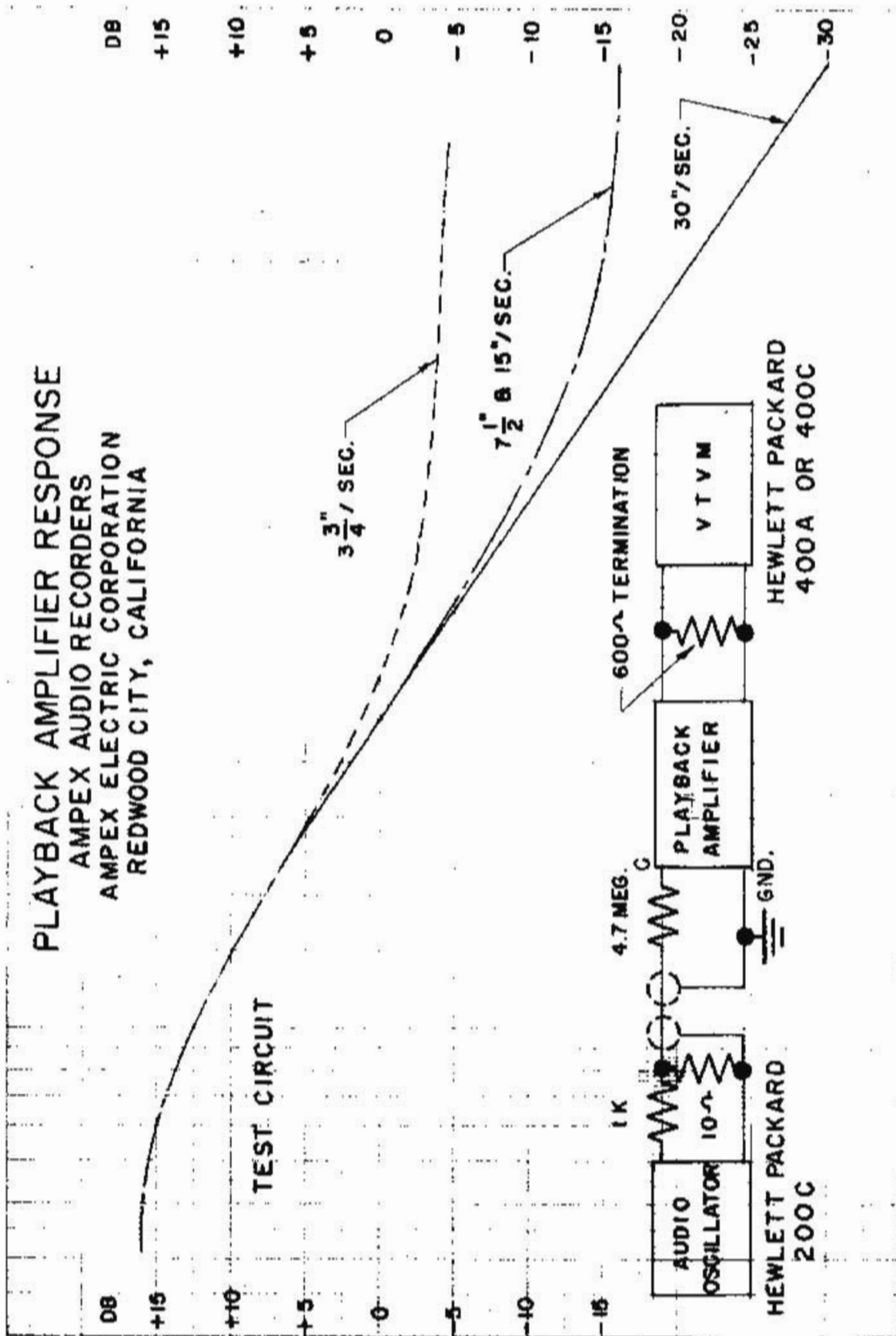
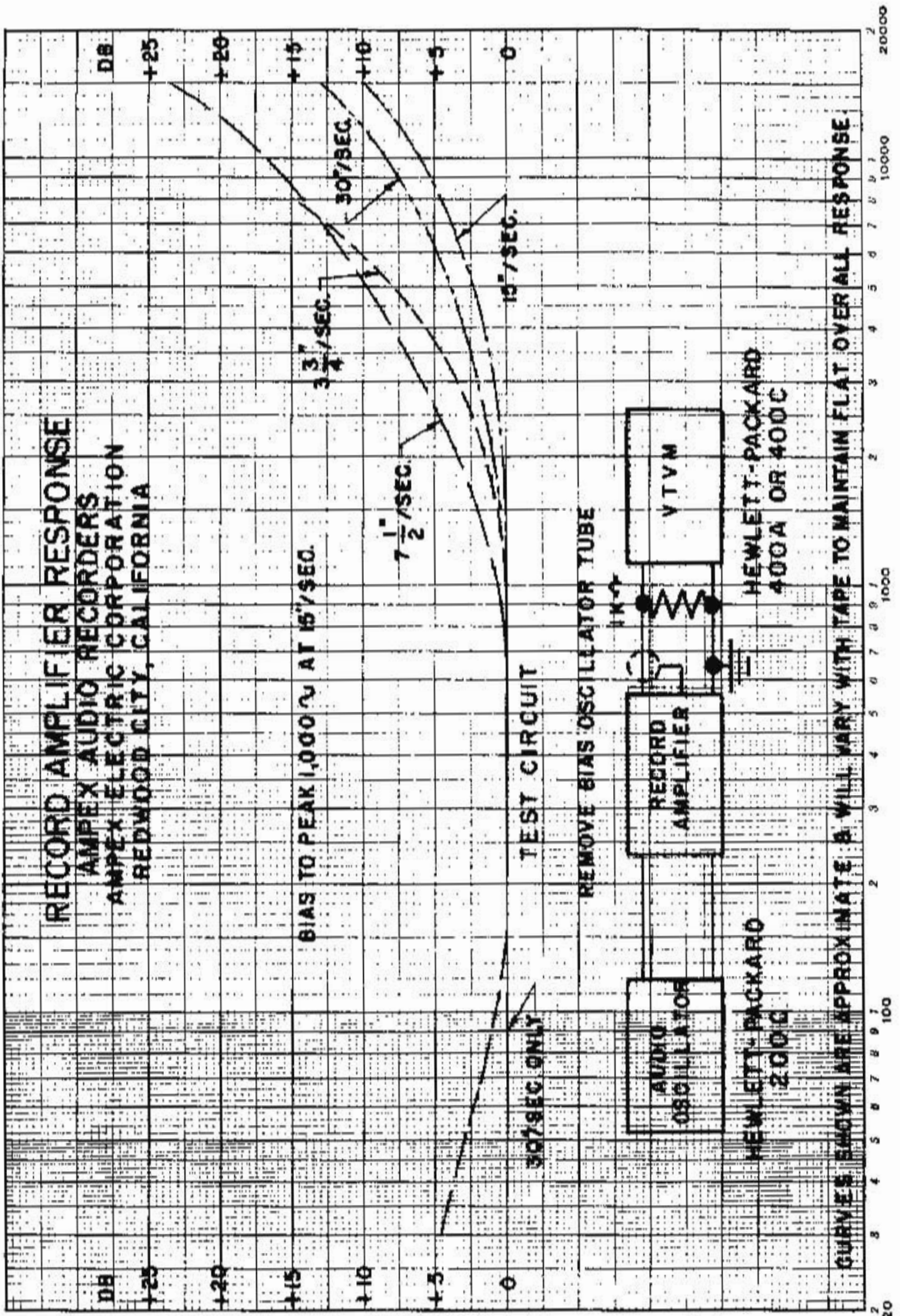

FIG 6

A-4477 5-1-53





A-4478

5-1-53

FIG. 7



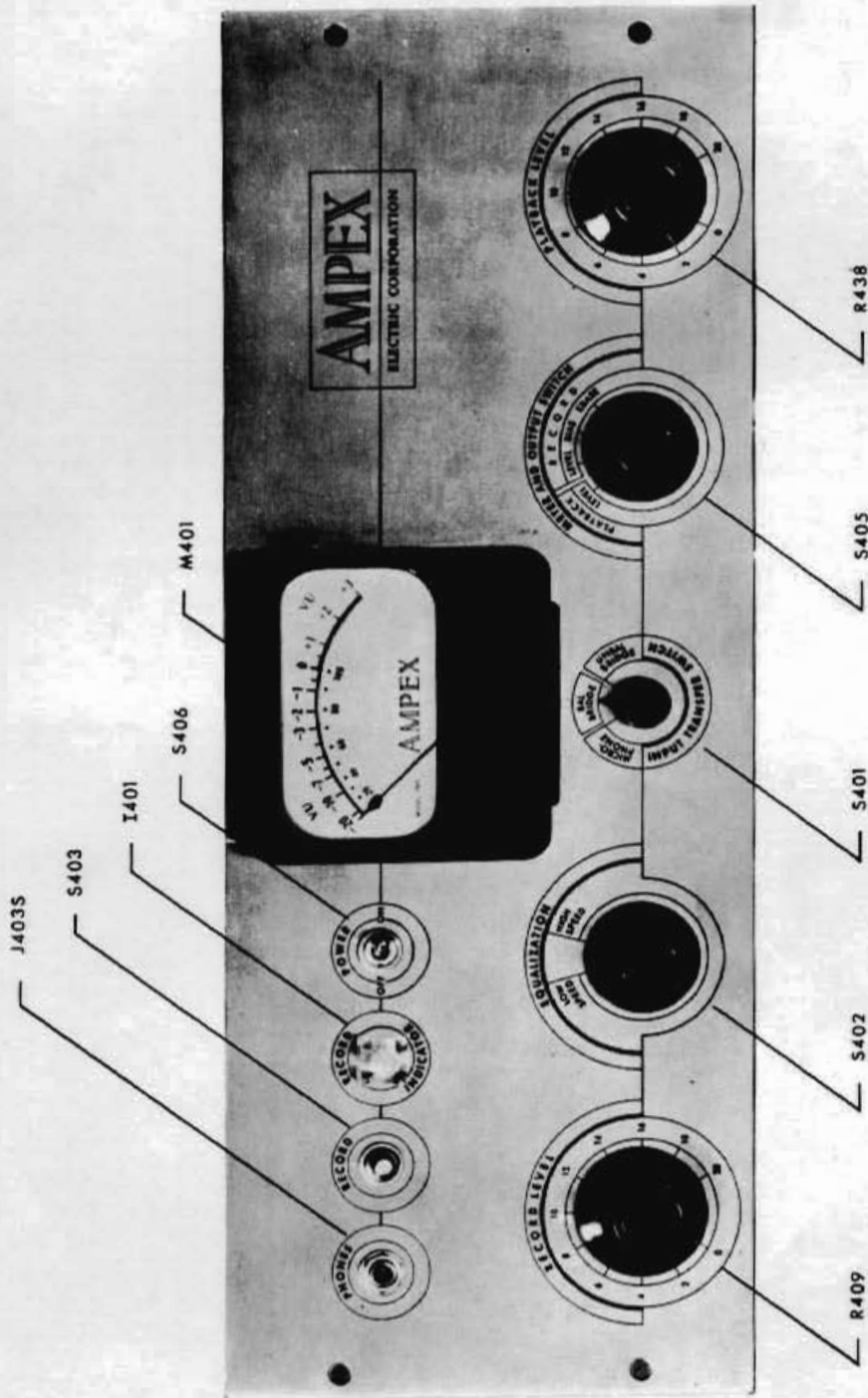

ELECTRONIC ASSEMBLY  
 FRONT PANEL  
 CATALOG NO. 5701  
 AMPEX ELECTRIC CORPORATION  
 REDWOOD CITY, CALIFORNIA

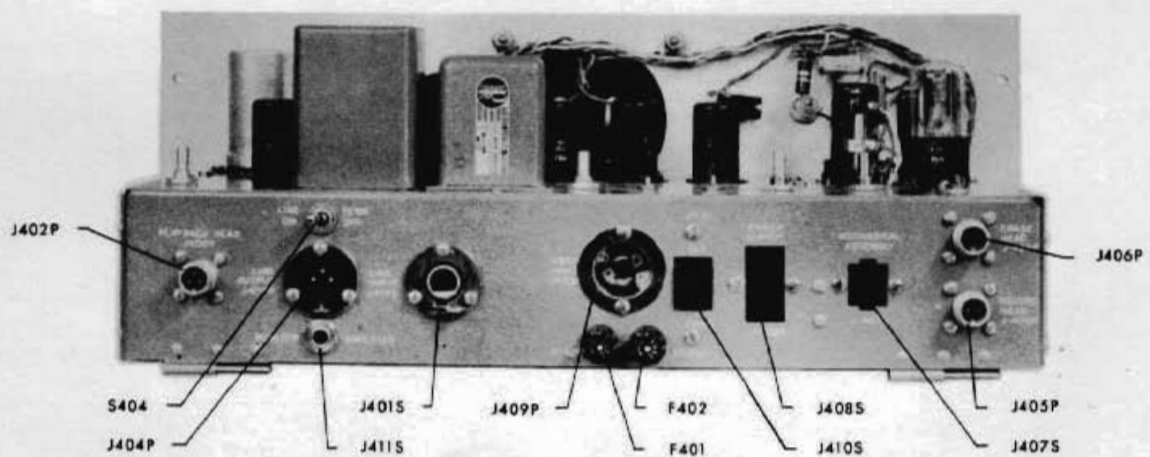
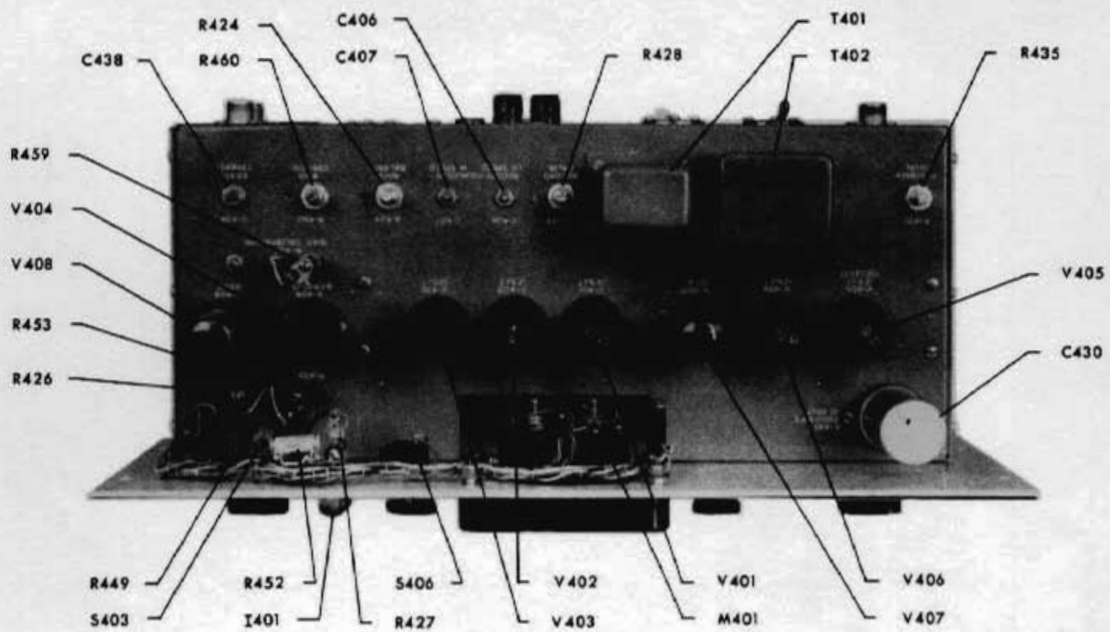

ELECTRONIC ASSEMBLY  
 TOP & REAR VIEWS  
 CATALOG NO. 5701  
 AMPEX ELECTRIC CORPORATION  
 REDWOOD CITY, CALIFORNIA

FIG. 9

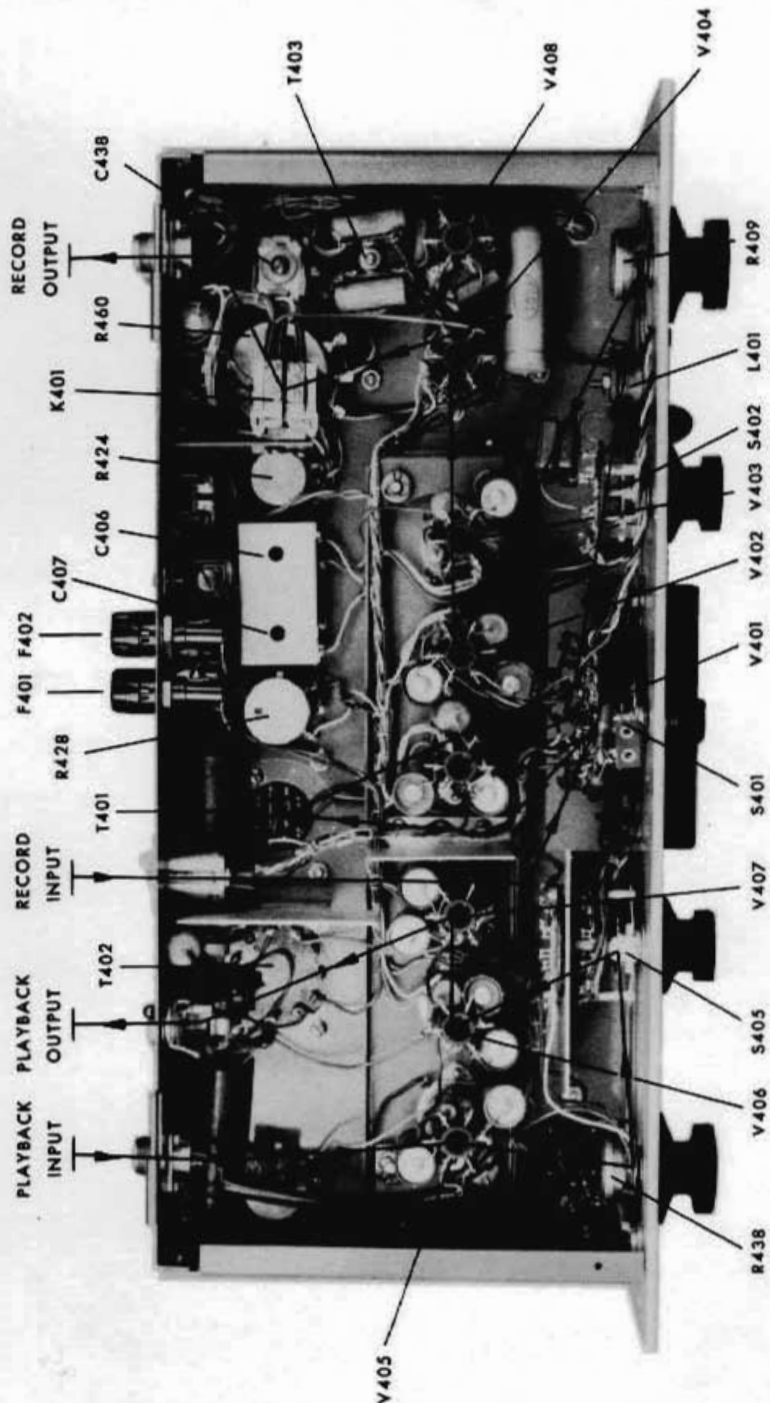

ELECTRONIC ASSEMBLY  
 BOTTOM VIEW  
 CATALOG NO. 5701  
 AMPEX ELECTRIC CORPORATION  
 REDWOOD CITY, CALIFORNIA

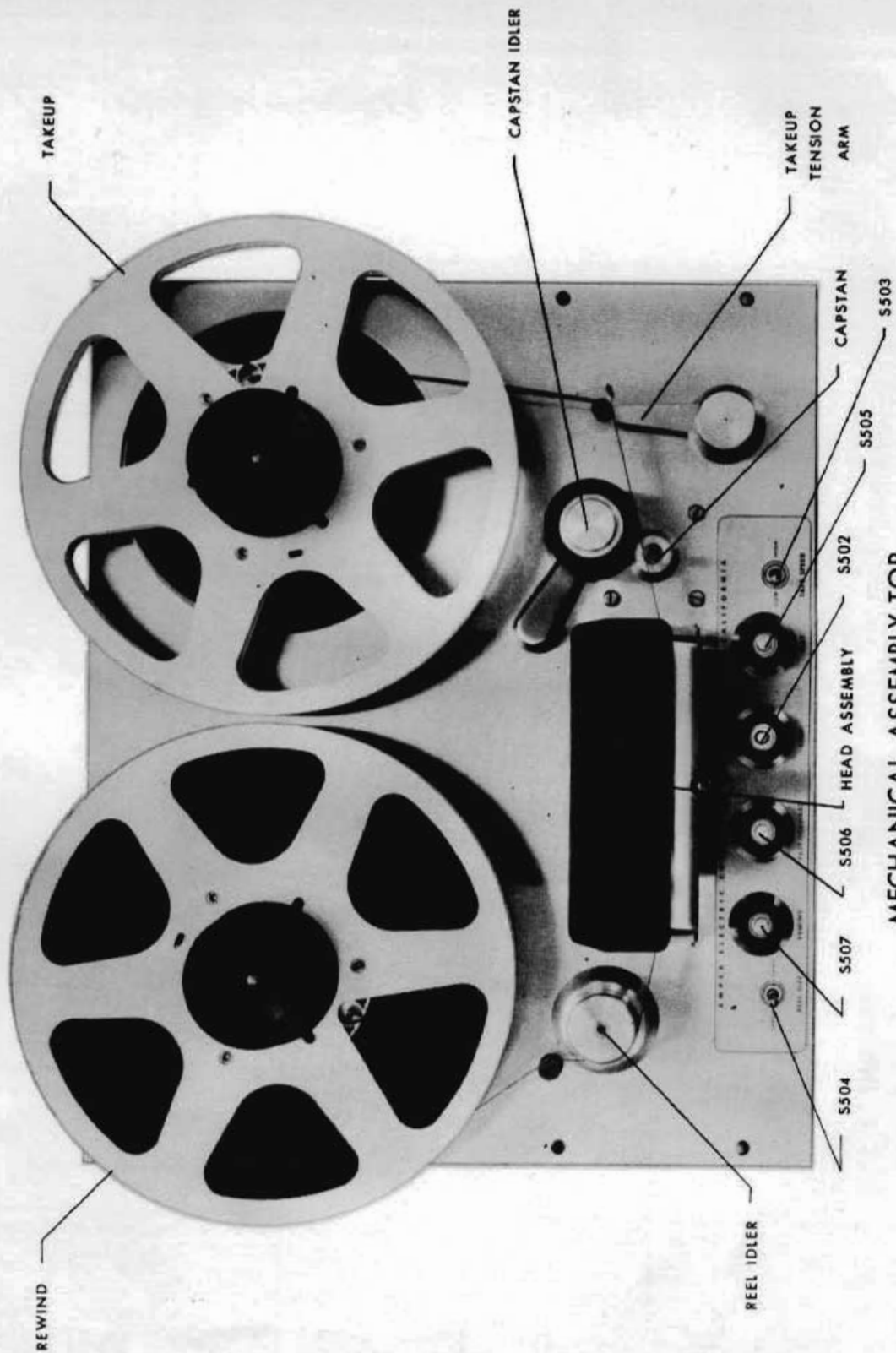

**MECHANICAL ASSEMBLY-TOP**  
**CATALOG NO. 5700**  
**AMPEX ELECTRIC CORPORATION**  
 REDWOOD CITY, CALIFORNIA

FIG. 11

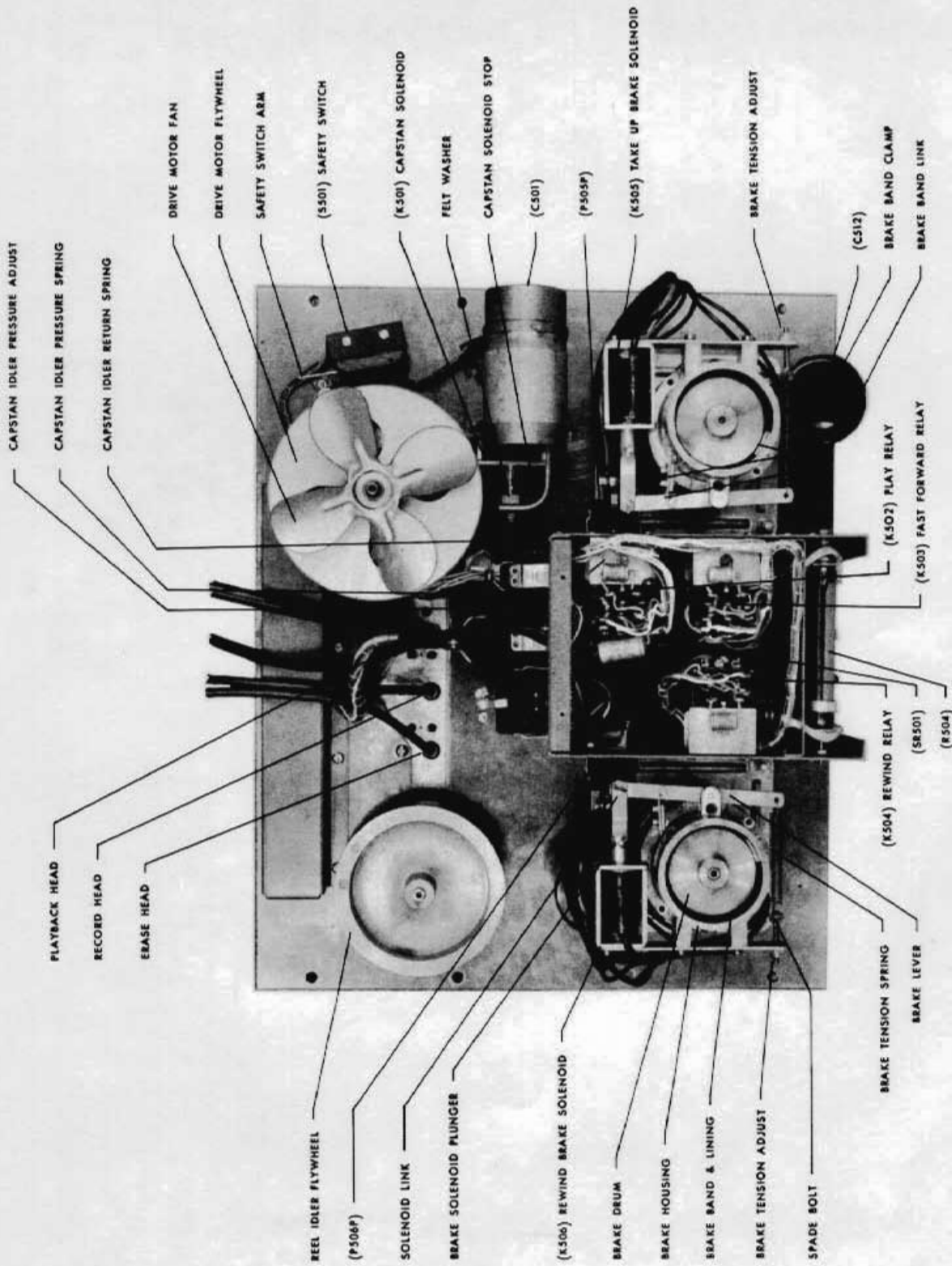

MECHANICAL ASSEMBLY - BOTTOM  
 CATALOG NO. 5700  
 AMPEX ELECTRIC CORPORATION  
 REDWOOD CITY, CALIFORNIA



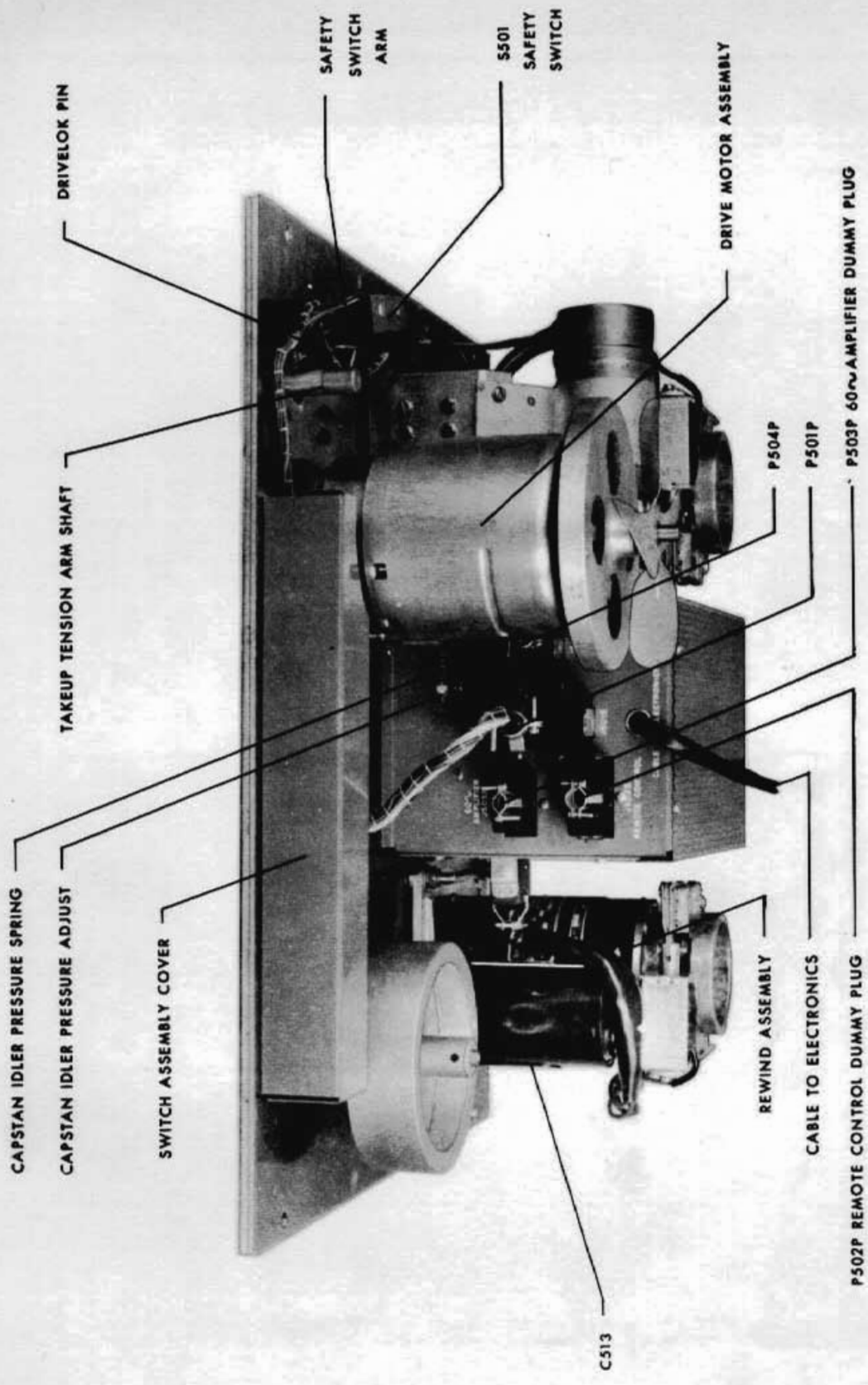

MECHANICAL ASSEMBLY-BOTTOM-FRONT  
 CATALOG NO. 5700  
 AMPEX ELECTRIC CORPORATION  
 REDWOOD CITY, CALIFORNIA

FIG. 13

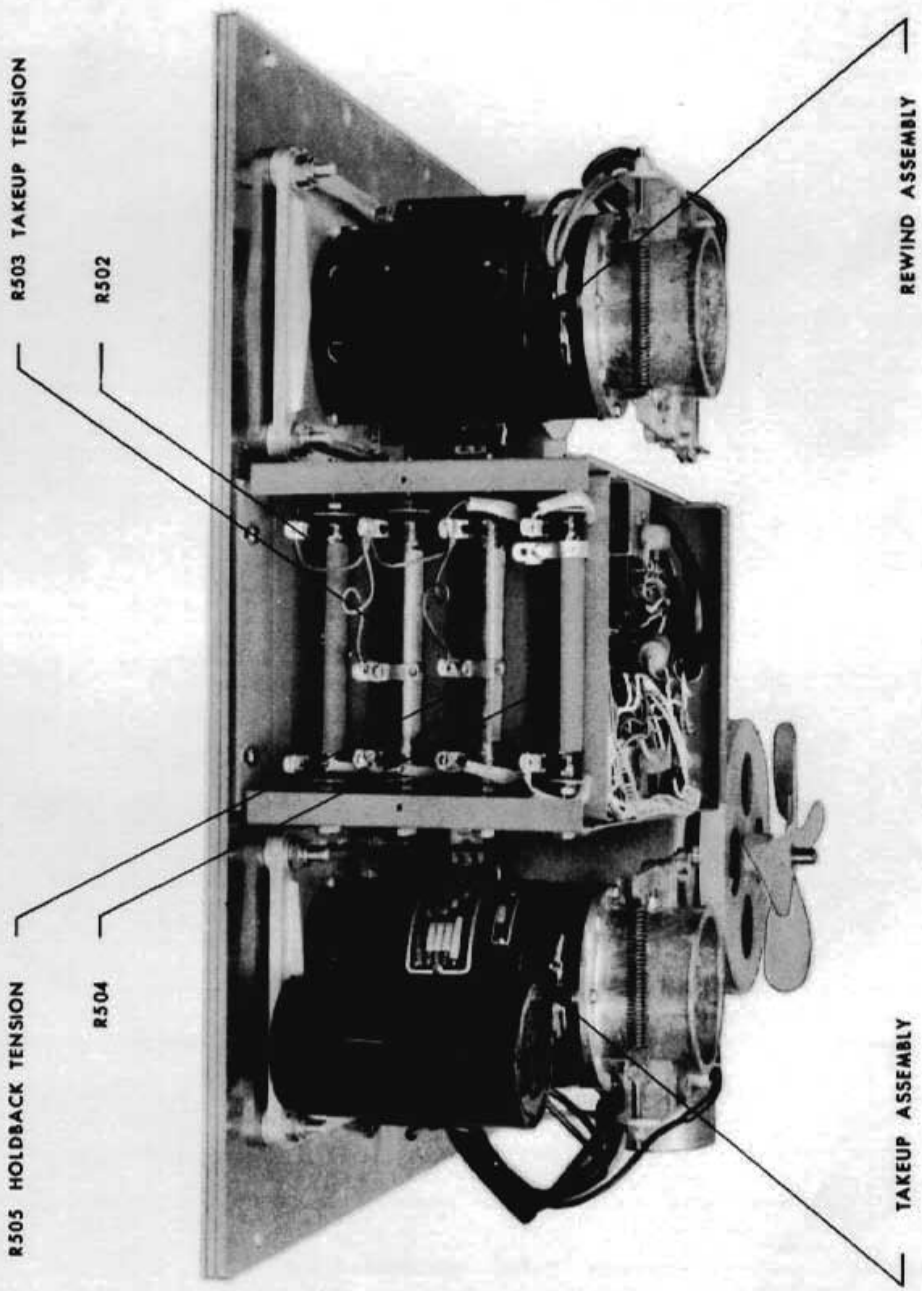

MECHANICAL ASSEMBLY-BOTTOM-REAR  
CATALOG NO. 5700  
AMPEX ELECTRIC CORPORATION  
REDWOOD CITY, CALIFORNIA

FIG. 14



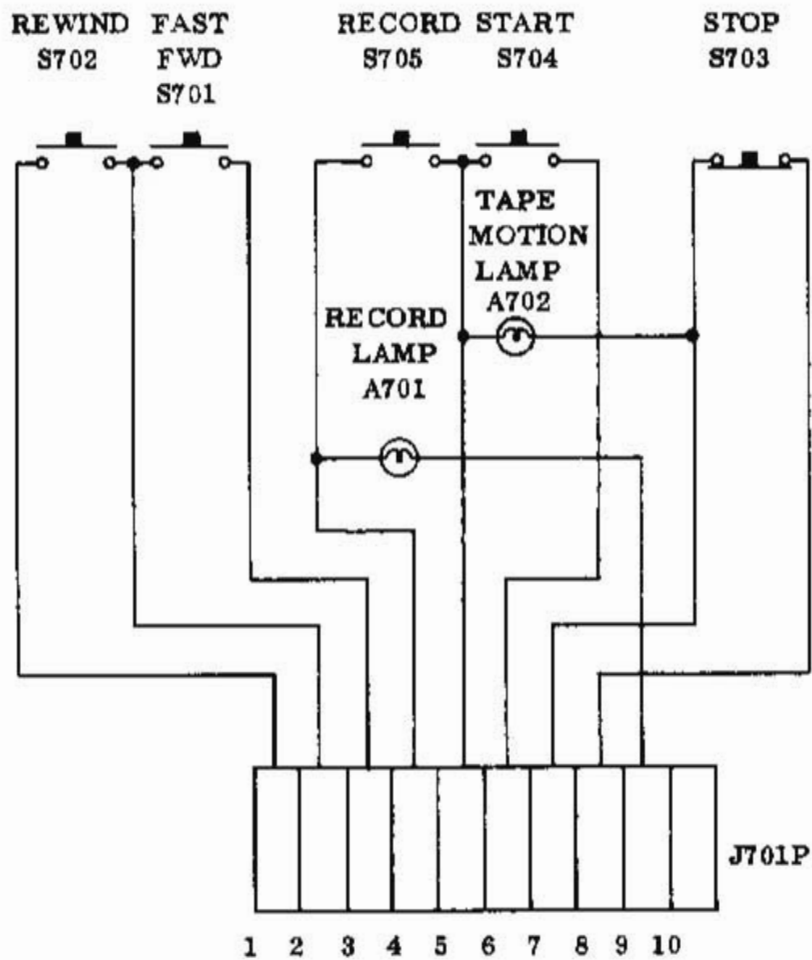
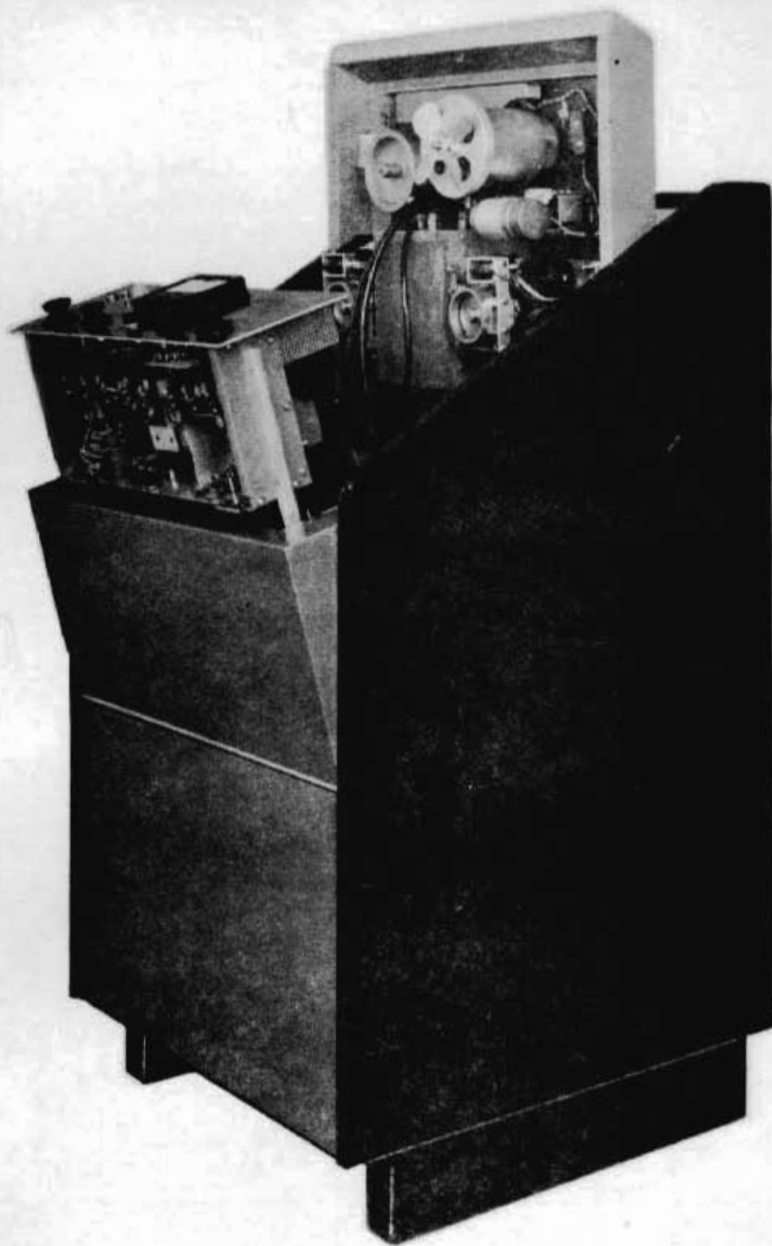
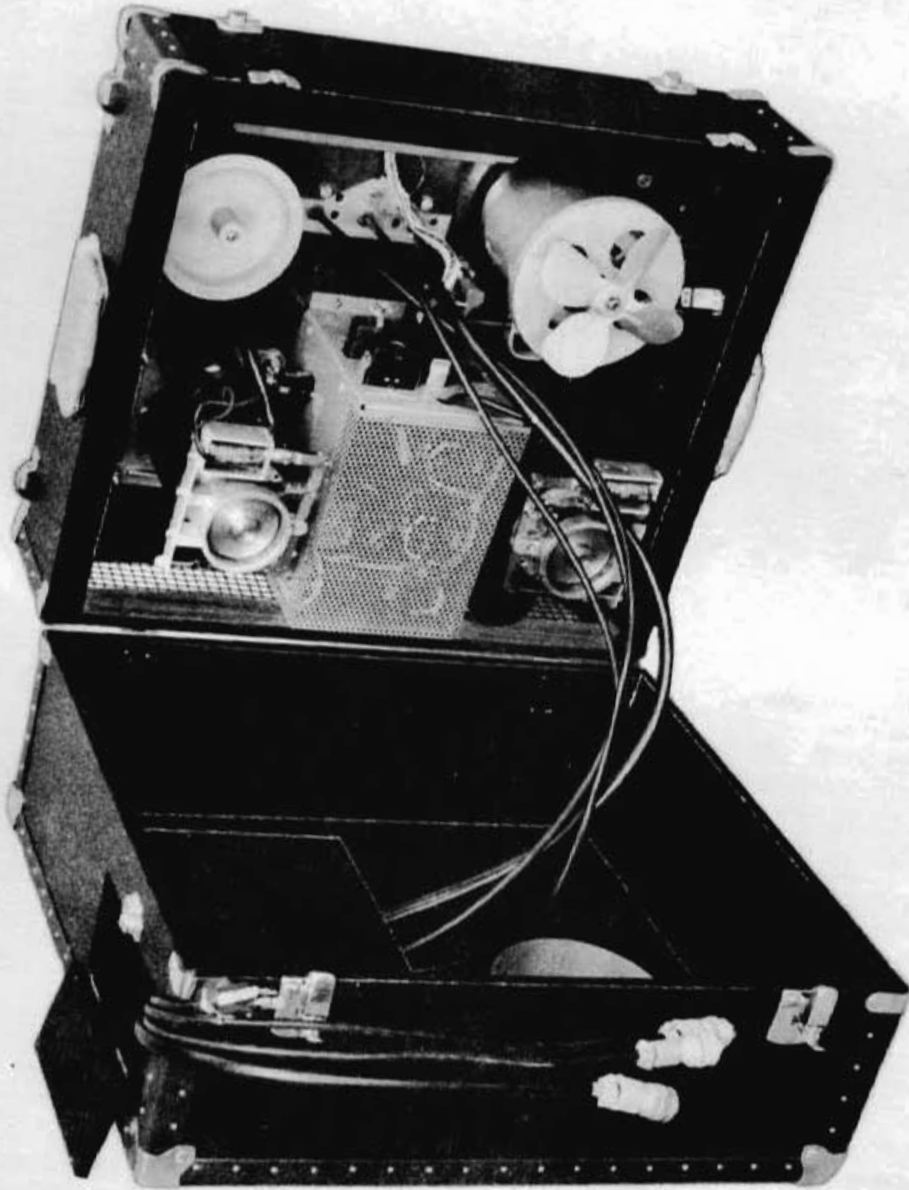

FIG. 15. SCHEMATIC DIAGRAM, REMOTE CONTROL UNIT



CONSOLE SERVICE ACCESS  
MODEL 350  
AMPEX ELECTRIC CORPORATION  
REDWOOD CITY, CALIFORNIA

FIG. 16



MECHANICAL ASSEMBLY SERVICE ACCESS  
CATALOG NO. 5700 (PORTABLE)  
AMPEX ELECTRIC CORPORATION  
REDWOOD CITY, CALIFORNIA

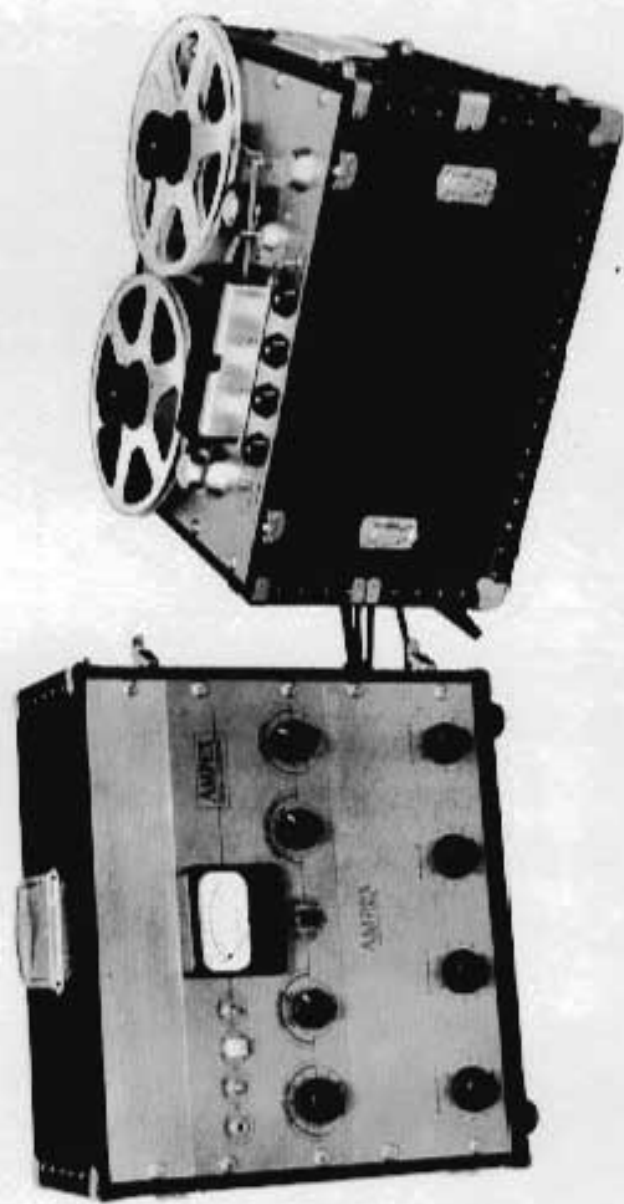

MODEL 350 TWO CASE PORTABLE  
(WITH FOUR CHANNEL MIXER)  
AMPEX ELECTRIC CORPORATION  
REDWOOD CITY, CALIFORNIA

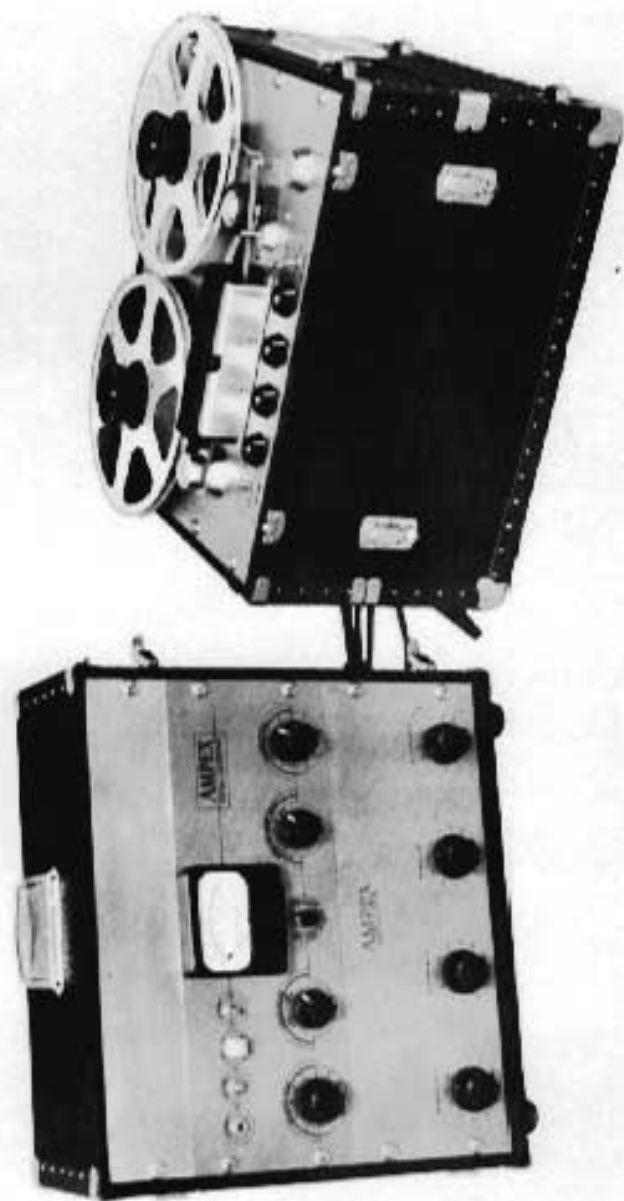

MODEL 350 TWO CASE PORTABLE  
(WITH FOUR CHANNEL MIXER)  
AMPEX ELECTRIC CORPORATION  
REDWOOD CITY, CALIFORNIA

# AMPEX

## CORPORATION

934 CHARTER ST. • EMERSON B-1471  
7WX REDWOOD CITY CAL 41  
CABLE ADDRESS: AMPEX, REDWOOD CITY  
REDWOOD CITY, CALIFORNIA

MAGNETIC RECORDERS

SERVICE BULLETIN

DATE: 19 April 1955  
MODEL: 350  
BULLETIN NO: 1  
PAGE NO: 1 of 2  
(Supersedes Service  
Bulletin #4, dated  
31 August 1954)

### MODEL 350 CONVERSION 7 $\frac{1}{2}$ "-15" to 3-3/4"-7 $\frac{1}{2}$ " IPS

The following outline is a complete procedure for converting a Model 350 operating at 7 $\frac{1}{2}$ "-15" to a Model 350 operating at 3-3/4" - 7 $\frac{1}{2}$ ". Care should be taken to follow the instructions closely. If care is taken, very little conversion difficulty will be encountered.

The following parts are needed for this conversion:

#### ELECTRONICS

1 - CO-122 Condenser  
1 - CO-325 Condenser  
1 - CO-230 Condenser  
1 - CO-12 Condenser  
1 - RE-608 Resistor

#### TOP PLATE

1 - 4459-3 Reel Idler Assembly  
1 - 6092 Capstan Idler  
1 - 5585 Capstan Drive Motor  
1 - 5632 Capstan Guard

#### ELECTRONICS

#### Record Amplifier

The following components should be changed to the specified values in the record amplifier:

C406 - .0005 mfd to .0003 mfd  
C407 - .0001 mfd to .0005 mfd  
C425 - .005 mfd to .015 mfd  
C426 - .0025 mfd to .005 mfd

#### Playback Amplifier

Wire unused section of equalization switch S402 into the playback equalization circuit so that C417 (schematic reference number) is connected to the switch's common connector. Break the connection between C417 and R435. Connect the loose end of R435 to a connector lug on this unused section of switch S402 so that an electrical path is made between R435 and C417 when the switch is in the high speed position. Now insert a new resistor (R462-33K + 1%) from the switch common connector to the junction of R435 and the plate of W405 (first tube in the playback amplifier).

Electronic conversion is now complete. Reset 7 $\frac{1}{2}$ " playback equalization curve so that it will conform to published curve located in the instruction manual. The 3-3/4" playback equalization should operate properly.

# AMPEX

## CORPORATION

934 CHARTER ST. - EMERSON 8-1471  
TWX REDWOOD CITY CAL 47  
CABLE ADDRESS: AMPEX, REDWOOD CITY  
REDWOOD CITY, CALIFORNIA

MAGNETIC RECORDERS

SERVICE BULLETIN

April, 1955

Model 350

BULLETIN NO.

PAGE NO. 2

(Supersedes Service Bulletin  
#1 dated 31 August 1954)

The record amplification should be checked against published curves on both speeds.

Set up complete recorder and make any further adjustments necessary so that the recorder's operation will meet the specifications.

### TOP PLATE

Remove the reel idler flywheel from its shaft by loosening the allen set screw which is located in the lower neck of the flywheel. Now remove the two hex head bolts which hold the reel idler to the top plate and lift idler off. Reverse procedure for installation. Care should be taken when installing the idler so that the brass spacer is placed between the idler and flywheel. Sufficient clearance of approximately 5 mils should be allowed so that the flywheel will turn freely after it is mounted in its proper position.

Loosen allen set screw located in end of capstan idler arm and remove the capstan idler. When replacing the idler care should be taken so that when the idler is in its proper position the tape will bisect the rubber tire surface of the idler. Reverse this procedure when installing new idler.

NOTE: If drive motor replacement is necessary, install motor before replacing capstan idler.

To install a new drive motor it is first necessary to remove the capstan idler so that the drive motor mounting screws are accessible, then remove the capstan dust cap #2667. Next, disconnect the drive motor power plug from the top plate control box. Loosen the four screws adjacent to the capstan on the top of the tape transport and gently lower the drive motor. When replacing a new drive motor, caution should be taken so that the proper motor condenser is used with the intended motor. Also care should be taken so that the capstan shaft is not bumped or damaged in any way. Next replace the capstan dust cap #2667 with the combination cap and capstan guard #5632 taking care not to damage the new capstan.

Now that the 3-3/4 - 7 1/2" conversion has been made on the top plate, it will now be necessary to readjust the capstan idler arm so that the idler wheel will present sufficient force to the tape and capstan shaft. Section 4.5.3 in the Model 350 manual outlines this procedure.



# AMPEX

## CORPORATION

934 CHARTER ST. • EMERSON B-1471  
7WX REDWOOD CITY CAL 41  
CABLE ADDRESS: AMPEX, REDWOOD CITY  
REDWOOD CITY, CALIFORNIA

MAGNETIC RECORDERS

SERVICE BULLETIN

DATE: 19 April 1955  
MODEL: 350  
BULLETIN NO: 1  
PAGE NO: 1 of 2  
(Supersedes Service  
Bulletin #4, dated  
31 August 1954)

### MODEL 350 CONVERSION 7 $\frac{1}{2}$ "-15 to 3-3/4-7 $\frac{1}{2}$ " IPS

The following outline is a complete procedure for converting a Model 350 operating at 7 $\frac{1}{2}$ "-15" to a Model 350 operating at 3-3/4" - 7 $\frac{1}{2}$ ". Care should be taken to follow the instructions closely. If care is taken, very little conversion difficulty will be encountered.

The following parts are needed for this conversion:

#### ELECTRONICS

1 - CO-122 Condenser  
1 - CO-325 Condenser  
1 - CO-230 Condenser  
1 - CO-12 Condenser  
1 - RE-608 Resistor

#### TOP PLATE

1 - 4459-3 Reel Idler Assembly  
1 - 6092 Capstan Idler  
1 - 5585 Capstan Drive Motor  
1 - 5632 Capstan Guard

#### ELECTRONICS

#### Record Amplifier

The following components should be changed to the specified values in the record amplifier:

C406 - .0005 mfd to .0003 mfd  
C407 - .0001 mfd to .0005 mfd  
C425 - .005 mfd to .015 mfd  
C426 - .0025 mfd to .005 mfd

#### Playback Amplifier

Wire unused section of equalization switch S402 into the playback equalization circuit so that C417 (schematic reference number) is connected to the switch's common connector. Break the connection between C417 and R435. Connect the loose end of R435 to a connector lug on this unused section of switch S402 so that an electrical path is made between R435 and C417 when the switch is in the high speed position. Now insert a new resistor (R462-33K + 1%) from the switch common connector to the junction of R435 and the plate of W405 (first tube in the playback amplifier).

Electronic conversion is now complete. Reset 7 $\frac{1}{2}$ " playback equalization curve so that it will conform to published curve located in the instruction manual. The 3-3/4" playback equalization should operate properly.

# AMPEX

## CORPORATION

934 CHARTER ST. • EMERSON 8-1471  
TUX REDWOOD CITY CAL 47  
CABLE ADDRESS: AMPEX, REDWOOD CITY  
REDWOOD CITY, CALIFORNIA

MAGNETIC RECORDERS

SERVICE BULLETIN

April, 1955

Model 350

BULLETIN NO.

PAGE NO. 2

(Supersedes Service Bulletin  
#1 dated 31 August, 1954)

The record amplification should be checked against published curves on both speeds.

Set up complete recorder and make any further adjustments necessary so that the recorder's operation will meet the specifications.

### TOP PLATE

Remove the reel idler flywheel from its shaft by loosening the allen set screw which is located in the lower neck of the flywheel. Now remove the two hex head bolts which hold the reel idler to the top plate and lift idler off. Reverse procedure for installation. Care should be taken when installing the idler so that the brass spacer is placed between the idler and flywheel. Sufficient clearance of approximately 5 mils should be allowed so that the flywheel will turn freely after it is mounted in its proper position.

Loosen allen set screw located in end of capstan idler arm and remove the capstan idler. When replacing the idler care should be taken so that when the idler is in its proper position the tape will bisect the rubber tire surface of the idler. Reverse this procedure when installing new idler.

NOTE: If drive motor replacement is necessary, install motor before replacing capstan idler.

To install a new drive motor it is first necessary to remove the capstan idler so that the drive motor mounting screws are accessible, then remove the capstan dust cap #2667. Next, disconnect the drive motor power plug from the top plate control box. Loosen the four screws adjacent to the capstan on the top of the tape transport and gently lower the drive motor. When replacing a new drive motor, caution should be taken so that the proper motor condenser is used with the intended motor. Also care should be taken so that the capstan shaft is not bumped or damaged in any way. Next replace the capstan dust cap #2667 with the combination cap and capstan guard #5632 taking care not to damage the new capstan.

Now that the 3-3/4 - 7 1/2" conversion has been made on the top plate, it will now be necessary to readjust the capstan idler arm so that the idler wheel will present sufficient force to the tape and capstan shaft. Section 4.5.3 in the Model 350 manual outlines this procedure.

## TABLE OF CONTENTS

SECTION 1	SPECIFICATIONS
SECTION 2	INSTALLATION
	2.1 Mounting and Interconnecting
	2.2 A. C. Power
	2.3 Output
	2.4 Input
	2.5 Phones
	2.6 Remote Control
	2.7 60 Cycle Amplifier
	2.8 Access to Console Cabinet
	2.9 Access to Underside of Mechanical Assembly Case in Two Case Portable
	2.10 Overall Performance Check
SECTION 3	OPERATING PROCEDURE
	3.1 Reel Size and Reel Knobs
	3.2 Tape Threading
	3.3 Half Track Operation
	3.4 Power
	3.5 Speed Switches
	3.6 Tape Motion
	3.6.1 Editing and Cueing Techniques
SECTION 4	TAPE TRANSPORT MECHANISM
	4.1 Major Assemblies
	4.2 Tape Tension System
	4.2.1 Brake Operation
	4.2.2 Reel Size Switch
	4.3 Relay Operation
	4.3.1 Play
	4.3.2 Rewind
	4.3.3 Fast Forward
	4.3.4 Stop
	4.3.5 Safety Interlocks
	4.4 Routine Maintenance
	4.4.1 Cleaning
	4.4.2 Lubrication
	4.4.3 Head Demagnetization

- 4.5 Adjustments
  - 4.5.1 Takeup and Rewind Tension
  - 4.5.2 Brake Tension
  - 4.5.3 Capstan Idler Pressure
- 4.6 Replacement of Parts
  - 4.6.1 Packing Precautions for Motors
  - 4.6.2 Brake Reconditioning and Replacement

## SECTION 5 ELECTRONIC ASSEMBLY

- 5.1 Record Amplifier
- 5.2 Playback Amplifier
- 5.3 Bias and Erase Oscillator
- 5.4 VU Meter and Monitoring
- 5.5 Power Supply
- 5.6 Electronic Alignment
  - 5.6.1 Alignment and Test Equipment Requirements
  - 5.6.2 General Precautions
  - 5.6.3 Playback Circuit Alignment
  - 5.6.4 Erase and Record Circuit Alignment

## SECTION 6 PARTS LIST

- 6.1 Model 350 (Complete Equipment)
- 6.2 Tape Transport Mechanism
- 6.3 Electronic Assembly
- 6.4 Miscellaneous

FIGURES A, B, C	Tape Tension System
FIGURES D, E	Brake Operation
FIGURE 0	Reel Hold-Down Knob
FIGURE 1	Electronic Assembly (7 1/2"-15")
FIGURE 2	Electronic Assembly (3 3/4"-7 1/2")
FIGURE 3	Tape Transport Control Circuits
FIGURE 4	Power Supply
FIGURE 5	Input
FIGURE 6	Playback Equalization Curves
FIGURE 7	Record Equalization Curves
FIGURE 8	Electronic Assembly - Front Panel
FIGURE 9	Electronic Assembly - Top and Rear
FIGURE 10	Electronic Assembly - Bottom
FIGURE 11	Tape Transport Mechanism - Top
FIGURE 12	Tape Transport Mechanism - Bottom
FIGURE 13	Tape Transport Mechanism - Bottom-Front
FIGURE 14	Tape Transport Mechanism - Bottom-Rear

**FIGURE 15**  
**FIGURE 16**  
**FIGURE 17**

**Remote Control Unit**  
**Console Service Accessibility**  
**Mechanical Assembly Service Access -**  
**(Portable)**